

---

# IN-PLANE TESTING OF DAMAGED MASONRY WALL REPAIRED WITH FRP

Amir Fam\*<sup>1</sup>, Daniel Musiker<sup>2</sup>, Mervyn Kowalsky<sup>2</sup> and Sami Rizkalla<sup>2</sup>

<sup>1</sup>Dept. of Civil Eng., Queen's University, Kingston, Ontario, Canada K7L 3N6

<sup>2</sup>Civil Eng. Dept., North Carolina State University, Raleigh, NC, USA 27695-7533

(Received ; accepted )

## ABSTRACT

This paper describes the performance of a masonry wall repaired with glass fibre reinforced polymer, GFRP sheets. The original reinforced clay brick masonry wall was tested under in-plane lateral cyclic loading. Failure occurred due to yielding of the steel reinforcement and crushing of the bricks. After epoxy injection of the cracks and patching of the missing portions, the wall was repaired using GFRP sheets, applied in the horizontal and vertical directions, on one face of the wall, including the joint between the wall and concrete footing. The repaired wall was tested to failure in the same manner of the original wall. The results show that the strength and displacement capacities of the wall were completely restored and even exceeded the original capacities.

**KEYWORDS:** repair, masonry, clay brick, FRP, cyclic, retrofit, sheets, glass

## 1. INTRODUCTION

A large number of existing masonry walls are not designed with sufficient seismic resistance. Previous research has shown that using fibre reinforced polymers (FRP) for retrofit is a feasible solution to increase seismic strength and ductility of masonry walls [1]. Most of the reported research has focused on strengthening of undamaged masonry walls in the out-of-plane direction. Triantafillou (1998) [2] tested clay brick specimens reinforced with Carbon-FRP (CFRP) laminates, using beam tests, to simulate in-plane bending, and pointed out the importance of proper anchorage and development length. Reinhorn (1995) [3] conducted in-plane cyclic loading on masonry walls strengthened with GFRP and reported that the fabric fractured along the diagonal cracking that occurred in the wall. Laursen et al (1995) [4] tested a masonry wall to failure, which occurred due to diagonal cracking and crushing of the compression side. The wall was then repaired using CFRP and retested. Test results indicated 22 percent increase in the ultimate load in comparison to the original capacity, however, it should be mentioned that the repair scheme was a continuous wrapping of the wall, which could be impractical. A large survey of research related to rehabilitation of masonry structures has been reported by Musiker (2002) [5].

## 2. OBJECTIVES

The objective of this study is to examine the performance of a severely damaged and repaired clay brick masonry wall using GFRP sheets, applied on one side of the wall. This scheme is believed to be more practical and realistic for repair of existing masonry structures to increase their strength and ductility. The paper describes the details of the proposed repair scheme including the joint between the wall and the concrete footing as well as the structural performance of the wall before and after repair under in-plane lateral loading.

## 3. EXPERIMENTAL PROGRAM

The experimental program included two tests conducted on one large-scale reinforced masonry wall. The first test was carried on the original wall. The second test was conducted on the same specimen after it has been repaired using GFRP sheets.

### 3.1 Construction of Test Specimen

The test specimen was constructed among several specimens in an experimental program designed to examine the effect of steel reinforcement ratio and confining plates on the seismic behaviour of clay brick masonry walls [6]. A 2440 x 1220 x 460 mm heavily reinforced concrete footing was built. Thirteen No.6

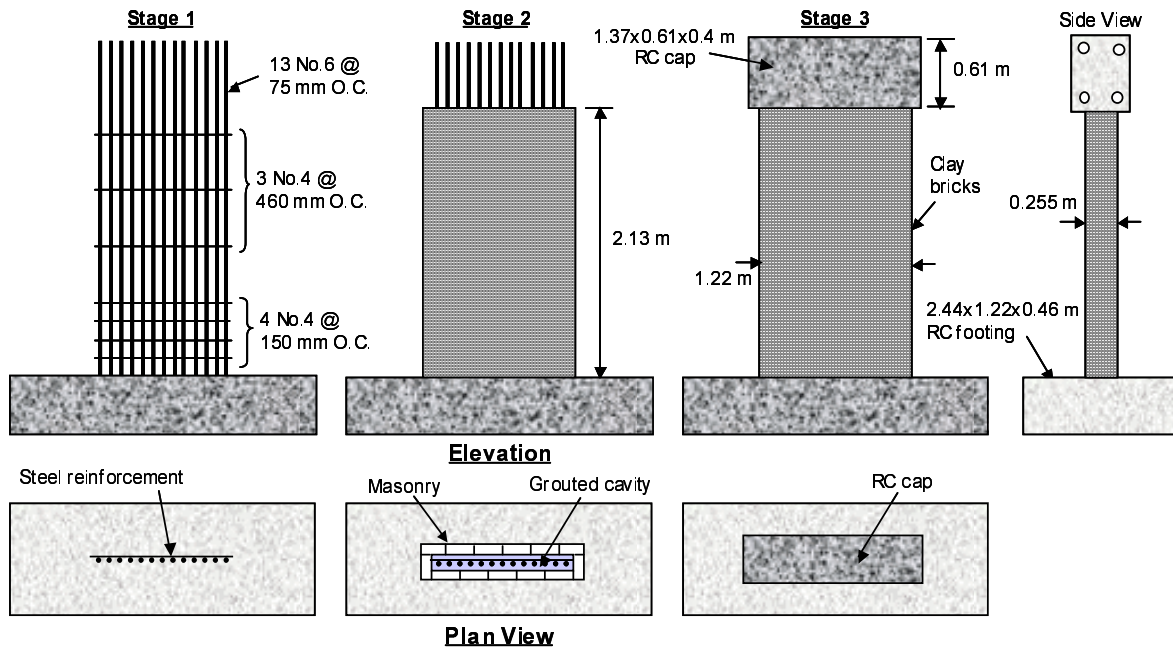

Fig. 1 : Different stages of construction of the masonry wall

(19 mm) reinforcing bars were embedded into the footing and extended 2740 mm above the face of the footing as shown in stage 1 of Fig. 1. The bars were projected along the centreline of the footing, at 75 mm spacing, parallel to the longer side of the footing. Horizontal shear reinforcement, 7 No. 4 (12 mm) bars, was connected to the longitudinal bars. The lower three bars were spaced at 150 mm, while the upper four bars were spaced at 460 mm. A 2135 x 1220 mm masonry wall was constructed above the footing, surrounding the projected reinforcement as shown in stage 2 of Fig. 1. Standard clay bricks were used in a double wythe in running bond, held together with type S mortar in concave joints. The total wall thickness was 255 mm, including a 70 mm cavity between wythes for

reinforcement. The cavity was later filled with standard grout. 3.2 mm thick and 380 mm long confining steel plates were used at both toe ends of the wall [6]. A 1370 x 610 x 405 mm reinforced concrete cap beam with an internal cavity to accommodate the projected ends of the reinforcement was placed on top of the masonry wall, then was grouted as shown in stage 3 of Fig. 1.

### 3.1 Test Setup of the Original Wall

The footing of the masonry wall was anchored to the strong floor using prestressed dywidag bars. A 980 kN MTS hydraulic actuator, anchored to a vertical structural wall, was connected to the cap beam of the masonry wall through a steel extender beam as shown in Fig. 2. The actuator had a

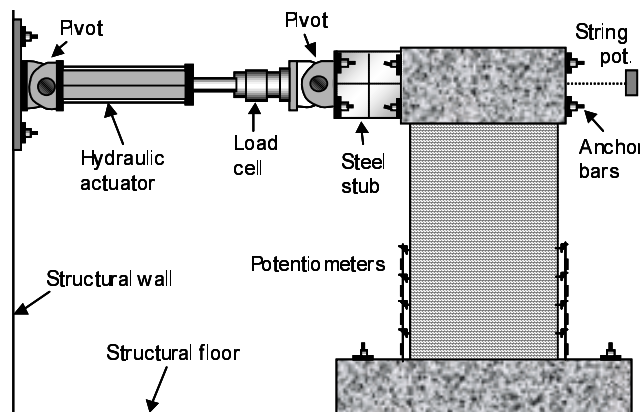
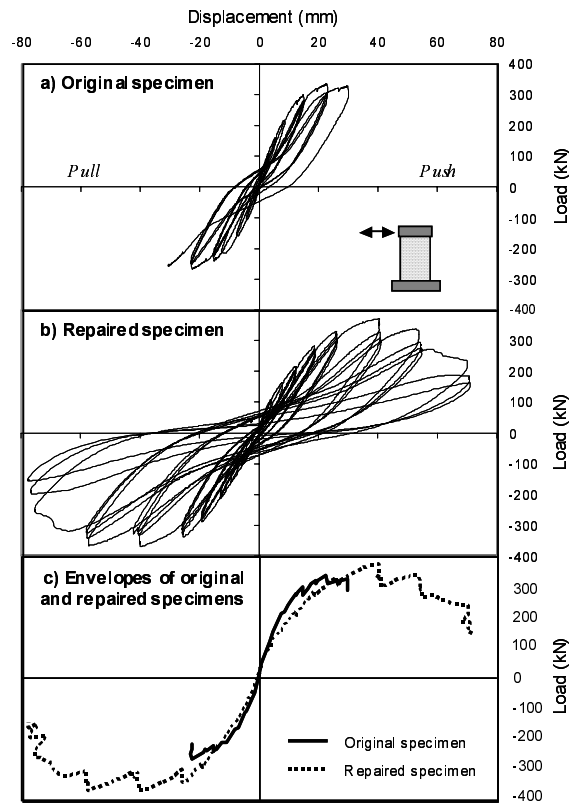

Fig. 2: Schematic of test setup and instrumentation



**Fig. 3 :** Load-displacement responses of the wall before and after repair

maximum stroke capacity of 1016 mm. A string potentiometer was used to monitor the in-plane lateral deflection of the wall at mid-height of the cap beam. Spring-loaded potentiometers were placed at both ends of the wall to measure the relative vertical displacements, which is used to obtain the base crack opening and strains as shown in Fig. 2. The wall was tested under reversed lateral cyclic loading to the theoretical yield load of 213 kN using load control and four full cycles of 53 kN increment. The yield displacement, 15 mm, was used to continue loading the wall under displacement control at increasing ductility levels of 1, 1.5, 2, 3, and 4 which correspond to 15, 23, 30, 46, and 61 mm lateral displacement, up to failure. Three full cycles were used for each level of displacement controlled loading. Details of the test procedure can be found in [6].

### 3.3 Results of Original Wall Test

The load-lateral displacement response of the first testing of the masonry wall is shown in Fig. 3(a) [6]. On the first cycle, a  $\pm 53$  kN load was applied and the wall deflected 1 mm. Few flexural cracks opened

within the lower 490 mm of the wall including the wall-footing interface. In the second cycle, a  $\pm 107$  kN was applied and the wall deflected 3.6 mm. The present cracks extended and few new cracks were initiated. In the third cycle,  $\pm 160$  kN was applied and the wall deflected 6.2 mm. Flexural cracks extended within the lower 1120 mm of the wall. In the fourth cycle (first yield), the wall was loaded to  $\pm 213$  kN and deflected 9.8 mm. Previous cracks were extended but no new cracks were initiated. At 1045 mm from the base, flexural cracks began to incline at 45 degree, indicating the first sign of shear cracking. At displacement ductility 1, the measured load was 300 kN. Cracks extended within the entire length of the wall and shear cracking was becoming prominent. At displacement ductility 1.5, the maximum load achieved was 334 kN. Crack widths up to 0.25 mm were measured. Initial signs of crushing of the bottom mortar joint were observed. At displacement ductility 2, the wall achieved a force of 327 kN. Shear cracks up to 0.63 mm were measured. On the third cycle, the entire face shell of the bottom course of masonry had spalled. Displacement ductility 3 was the last full cycle



Fig. 4: Failure of the wall after first testing (cracking and crushing of bricks and mortar joints)

completed. The maximum force obtained was 324 kN. Flexural and shear cracks up to 1.27 mm and 1.52 mm respectively were observed and the second course of masonry on one end of the wall was crushed as shown in Fig. 4. On the other end of the wall, the bottom layer of mortar was crushed and spalled up to a depth of 390 mm. The mortar joints within a height of 280 mm also spalled over a depth of 290 mm. Due to the excessive damage and softening, which affected the stability of the wall, loading was terminated after the first cycle of displacement ductility 4.

### 3.4 GFRP Repair Scheme

All loose particles were removed using a hand grinder, wire brush, a hammer, chisel and a vacuum. The wall was readjusted to vertical position using straps and wire pulleys. The missing parts of the bricks in the compression zone as well as the mortar joints were patched with new cement mortar after being wetted and allowed to dry. All cracks were patched using a Quickseal Type Epoxy. During patching, injection ports were placed at different points over the surface on one side of the wall in order to inject epoxy grout into the wall. The epoxy grout had tensile strength and modulus of 51 MPa and 2.23 GPa respectively. As the epoxy grout leaked from ports on the opposite side of the wall and above, the hoses were moved up the wall and leaking ports were capped. Quick-setting hydro cement, dried with a heat gun, was used to stop

leaks from the surface. Later, the hydro cement and epoxy patches were removed from the surface using hammers. A grinder was then used to expose the brick faces, mortar joints and the upper face of the concrete footing to achieve good bond. Grinding revealed that cracks were closed tightly by the epoxy grout.

The GFRP repair scheme incorporated unidirectional E glass woven fabric, placed only on one face of the wall in the horizontal and vertical directions as well as a bi-directional fabric with fibres oriented at  $\pm 45$  degrees placed at the joint between the wall and footing as shown in Fig.5. Epoxy primer coat was applied to the wall, footing, and the unidirectional GFRP fabrics. The epoxy resin had tensile strength and modulus of 72 MPa and 3.18 GPa respectively. The horizontal unidirectional sheets were placed first with gaps of about 25 mm in between. Precautions were taken to ensure that the gaps spanned over the brick face and not at the joints. The vertical GFRP sheets were then placed over the horizontal sheets. A 50 mm radius was built up along the bottom of the wall using a mixture of epoxy and silica fume paste in order to eliminate sharp corner at the interface of the footing and wall. The L-shape bi-directional fabric was then laid up dry at the corner and saturated with epoxy resin as shown in Fig. 5. The GFRP repair system was left to cure for two weeks.

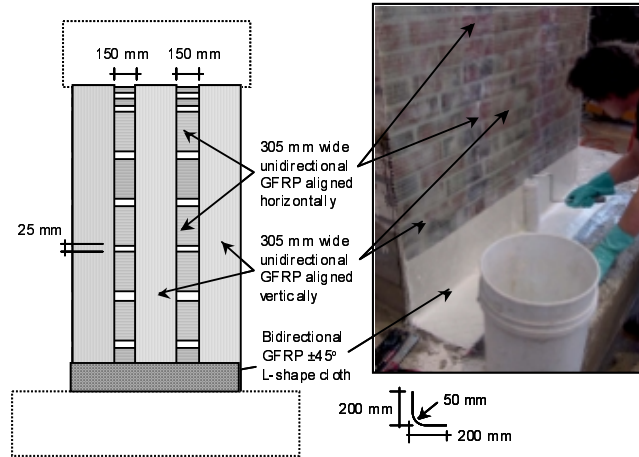

**Fig. 5:** Repair scheme of the damaged wall using GFRP

### 3.5 Behaviour and Failure Mode of the Repaired Wall

The repaired specimen was retested using the same test setup and loading history adopted for the original wall, shown in Fig. 2. Fig. 3(b) shows the load-displacement response of the repaired wall. The load-displacement envelopes of the original and repaired specimens are compared in Fig. 3(c). The repaired wall exhibited an initial stiffness lower than the original wall, however, the maximum load capacities of the repaired wall were 11 and 38 percent in the push and pull directions respectively. The repaired wall was able to endure three full cycles of  $\pm 76$  mm displacement-based loading (displacement ductility 5) as shown in Fig. 3(b), and was subsequently pushed to a maximum displacement of 203 mm before substantial damage of the concrete footing ended the test.

At early stages of load control, the base crack began to open. Fig. 6 shows the variation of relative vertical displacement between the wall and the base with the load for the original and repaired wall tests. The figure shows that the base crack opening is wider in the repaired specimen at any given load. This could be attributed to the softening of the interface after the first testing as well as to the fact that the presence of vertical GFRP sheets added stiffness to the wall and shifted the point of rotation towards the interface with the base. The upward force on the tension side produced peeling stresses on the horizontal side

of the L-shape bi-directional fabric, resulting in opening of the base crack. As the wall is pulled back the crack closes and eventually the compressive stresses produces crushing of the mortar joints and bricks at the interface with the base as indicated by the negative vertical displacement in Fig. 6. During the  $\pm 23$  mm cycles, vertical splitting of the masonry as well as delamination and outward local buckling of the vertical GFRP sheets occurred at the edge of the wall on one end, just above the L-shape GFRP bi-directional layer, as shown in Fig. 7(a). Through the  $\pm 30$  mm cycles, buckling of GFRP and cracking of masonry progressed. During the  $\pm 46$  mm cycles, buckling of GFRP and crushing of masonry increased on the other end. Through the  $\pm 61$  mm cycles, degradation of the wall continued where the repair mortar cracked and spalled. Also cracking of the footing became visible. The successive opening and closing of the interface crack between the wall and footing throughout the increasing loading cycles allowed the peeling process to propagate within large area of the horizontal side of the L-shape bi-directional fabric, causing separation from the concrete base as shown in Fig. 7(b). The final  $+ 76$  mm push displacement of the wall is shown in Fig. 7(c), which also shows excessive damage occurring in the concrete footing. Close inspection of the wall during and after the test revealed that a new pattern of cracks developed and that the old cracks did not open. It should also be noted that the capacity of the repaired wall was limited by the capacity of the

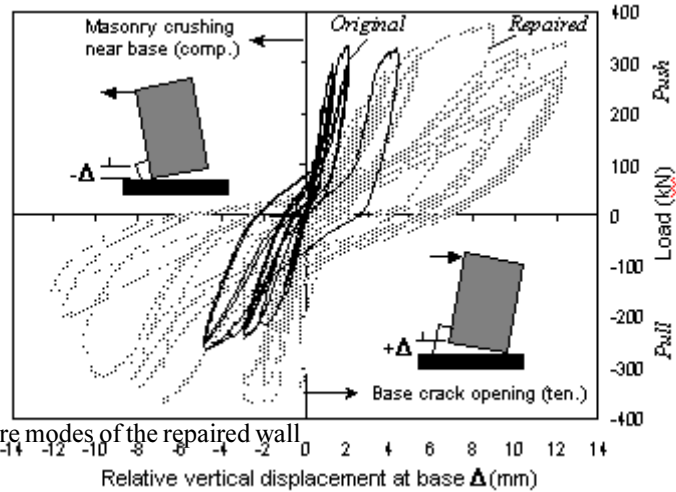

Fig. 7 Failure modes of the repaired wall

Fig. 6: Load-relative vertical displacement behaviour between wall and base

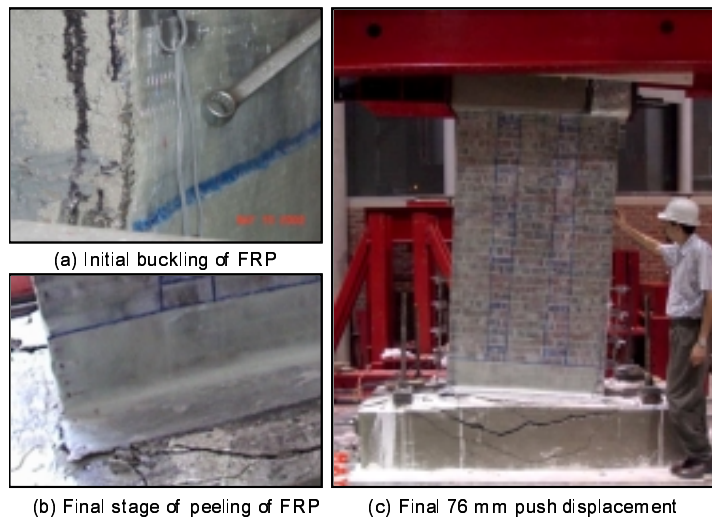

Fig. 7 : Failure modes of the repaired wall

concrete footing and even better behaviour would have been possible if the footing did not fail.

#### 4. CONCLUSIONS

A large-scale clay brick masonry wall has been tested to failure under lateral in-plane cyclic loading. The wall was repaired using a practical strengthening scheme of GFRP sheets and retested to failure. Test results indicate that the strength of the wall was restored and exceeded the original wall strength by 11 and 38 percent in the push and pull directions respectively. The displacement capacity of the repaired wall was more than twice that of the original wall. Further research is needed to improve the repair technique at the joint between wall and footing and to consider the various parameters affecting the behaviour of masonry walls.

#### ACKNOWLEDGEMENT

The authors wish to acknowledge Mr. Adrian Durham and Mr. Jerry Atkinson for their efforts during the experimental program. The authors also would like to acknowledge the Constructed Facilities Laboratory (CFL) of NC State University for using the facilities, the National Science Foundation (NSF) for sponsoring the project and Fyfe Co. LLC for conducting the repair using FRP.

#### References:

1. Laursen et al, "Seismic Retrofit and Repair of Masonry Walls with Carbon Overlays", Proc., 2<sup>nd</sup> Int. RI-LEM Symp. (1995), 616-623.
2. Triantafillou, T. C., "Strengthening of Masonry Structures Using Epoxy-Bonded FRP Laminates", Journal of Composites for Construction, ASCE, 2/2 (1998), 96-104.
3. Reinhorn, M., "Evaluation of Tyfo W Fibre Wrap

System for In-Plane Strengthening of Masonry Walls”, Test Report, No. AMR 95-0002, Dept. of Civil Eng., State U. of NY at Buffalo (1995).

4. **Laursen et al**, “Seismic Retrofit and Repair of Masonry Walls with Carbon Overlays”, Non-metallic (FRP) Reinforcement for Concrete Structures (1995), 616-623.
5. **Musiker, D.**, “Repair and Strengthening of Masonry Walls with Fibre Reinforced Polymers”, Master’s of Civil Engineering Project, North Carolina State University, 2002.
6. **Durham, A. S.**, “Influence of Confinement Plates on the Seismic Performance of Reinforced Clay, Brick Masonry Walls”, M.Sc. Thesis, North Carolina State University, 2002.