

Name _____

Student number _____

SE 4C03 Winter 2004

Sample Midterm Test

Instructor: Kartik Krishnan

You have 50 minutes to complete this test consisting of 6 pages and 18 questions. The test is open book and class notes. Do not consult anyone or anything else. Circle the *best* answer for the multiple choice questions, and write down the answers to other questions in the answer sheets provided, clearly labelling the question number. Be succinct and to the point. Good luck!

1. [3 pts.] A token ring network is a connection-oriented technology. Is this statement true or false?
 - (a) True.
 - (b) False.

2. [3 pts.] Slow-start refers to the slow increase in the congestion window after congestion. Is this statement true or false?
 - (a) True.
 - (b) False.

3. [3 pts.] A given TCP port number can be shared by multiple connections on the same machine. Is this statement true or false?
 - (a) True.
 - (b) False.

4. [3 pts.] Routers use the destination computer IP address, when forwarding a packet. Is this statement true or false?
 - (a) True.
 - (b) False.

5. [3 pts.] The purpose of the ICMP protocol is *not* to make IP more reliable?
 - (a) True.
 - (b) False.

6. [5 pts.] ARP is a _____ protocol.
- (a) Network Interface Layer.
 - (b) IP.
 - (c) TCP.
 - (d) connection oriented.
7. [5 pts.] In the TCP protocol, what is considered as a possible indicator of traffic congestion?
- (a) An unacknowledged TCP segment.
 - (b) More than 5 dropped TCP packets.
 - (c) The reception of an ICMP source quench message.
 - (d) All of the above.
8. [5 pts.] If an Internet host is running TCP/IP and IP forwarding is turned off, then
- (a) The host does not need a routing table.
 - (b) The host cannot send IP datagrams to other Internet hosts.
 - (c) IP datagrams cannot enter and then exit the host.
 - (d) All of the above.
9. [5 pts.] A router must always handle datagrams of up to
- (a) 1500 bytes.
 - (b) 576 bytes.
 - (c) Minimum MTU.
 - (d) 4470 octets.
10. [5 pts.] The basic unit of transfer in UDP is a
- (a) Packet.
 - (b) Segment.
 - (c) Datagram.
 - (d) Frame.

11. [5 pts.] Suppose that a process would like to transmit one octet of data to another process using UDP. How many UDP datagrams would normally be needed to perform the transmission?
- (a) 1.
 - (b) 2.
 - (c) 4.
 - (d) 8.
12. [5 pts.] Silly window syndrome can be avoided by
- (a) Karn's algorithm.
 - (b) Nagle's algorithm.
 - (c) Count-to-infinity.
 - (d) Fragmenting the IP datagram.
13. [5 pts.] An ICMP control message is generated for the following.
- (a) An ICMP packet is lost.
 - (b) The TCP connection times out.
 - (c) Incorrect UDP header.
 - (d) Time exceeded for a datagram.
14. [5 pts.] Explain with exactly one sentence the purpose of the loopback network interface.
15. [5 pts.] What kind of a handshake is needed by TCP to terminate a connection?. Why?
16. [5 pts.] Suppose that there is a TCP connection between A and B and that A has just sent five TCP segments S_1, \dots, S_5 to B whose sequence number fields contain 34456, 34578, 34672, 34790, 35155, respectively. After receiving S_1, S_2, S_4 but not S_3, S_5 , B sends a TCP segment T to A . What number will be in acknowledgement number field of T ?
17. [10 pts.] Consider a subnet whose subnet address is 202.111.96.0 and whose subnet mask is 255.255.224.0.
- (a) How many IP addresses are members of this subnet?
 - (b) How many class networks are subsets of this subnet?

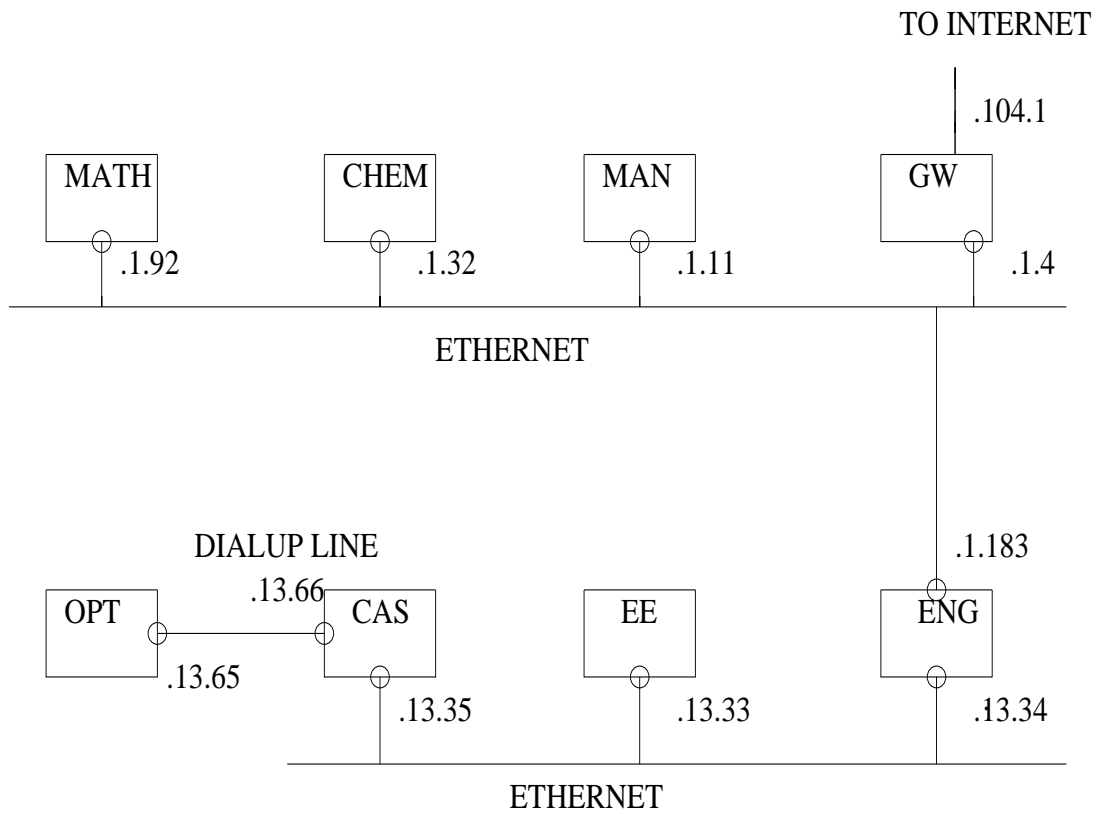

HYPOTHETICAL COMPUTER NETWORK IN MCMASTER UNIVERSITY
 CLASS B NETWORK WITH IP ADDRESS 140.252.0.0

Figure 1: Hypothetical Class B network at Mac.

18. [20 pts.] Consider a portion of the hypothetical Class B computer network with IP address 140.252.0.0 at McMaster University shown in Figure 1. The hosts shown are the various department servers, including a gateway router 140.252.104.1. Some of the hosts have two IP addresses as shown. The link between OPT and CAS is via a dial-up line. The upper and lower ethernet interfaces are eth0 and eth1 respectively.

- (a) How many subnets do you see?. What are the corresponding subnet masks?.
- (b) Let us say all hosts are configured to act as routers. Recall that a route in a subnet routing table has the form (a, m, r, i) where:
 - a is the address of a subnet S .
 - m is the mask of S .
 - r is an IP address for the “next hop” ($r = *$ for direct routes).
 - i is an interface.

Write down the routing table for host EE, including its loop-back interface lo, as a list of (a, m, r, i) tuples. *Use default or host-specific routes as necessary, and keep the number of indirect routes as small as possible.*