

Wideband High Dynamic Range Distortion Measurement

Jonathan R. Wilkerson, Kevin G. Gard, and Michael B. Steer

North Carolina State University, Department of Electrical and Computer Engineering,
Campus Box 7914, Raleigh, NC 27695-7914, U.S.A, Phone : +1-919-513-7366

Abstract—This paper presents an intermodulation distortion measurement system based on automated feedforward cancellation that achieves 95 dB of broadband dynamic range. A single tone cancellation formula is developed requiring only the power of the probing signal and the power of the combined probe and cancellation signal to predict the required phase shift for cancellation. This formula is applied to a two path feedforward cancellation system, combined with the DUT probe path in a bridge configuration. The dynamic range and cancellation capabilities of this system are confirmed by measuring the passive intermodulation distortion generated by a low PIM microwave chip termination. The cancellation method extends the intermodulation distortion measurement dynamic range by at least 20 dB.

I. INTRODUCTION

Intermodulation Distortion is usually the limiting factor in high dynamic range communication systems such as satellites and cellular basestations. To accurately model and design such systems, determination of underlying mechanisms responsible for system performance limitations must be found. Determination of these mechanisms requires a measurement system with a significantly higher dynamic range and tunability than currently available.

Dynamic range limitations in distortion measurement systems stem from the nature of the testing itself. As strong stimulus tones are applied to the device under test (DUT), nonlinearities are generated at much lower power levels. The distortion products in question can be easily masked by the high power signal initially applied. The interfering stimulus must be removed before reaching the receiver, where all important distortion information will be lost either by distortion generated at the receiver or by increased noise associated with the interfering stimulus [1]. Attenuation could be introduced to reduce or eliminate receiver nonlinearity, but this will both reduce the magnitude of nonlinearities and increase noise. To reduce both noise and carrier level simultaneously, filtering or active feedforward techniques [6] are needed.

High dynamic range measurement systems based on filtering use duplexers or notch filters to remove distortion components generated in the system before application to the device. A second filtering removes carrier components to allow full use of the spectrum analyzer dynamic range, unaffected by large probe signals. Such a scheme is extremely effective, but is also limited by filter bandwidths and the sharpness of duplexer skirts, and is not tunable without physically changing filters to cover other frequency bands.

Overcoming tunability limitations is of utmost importance when testing for passive intermodulation distortion (PIM), as some types of PIM such as electro-thermal distortion must be tested for at very small tone separations where no filter skirt

can be sharp enough. The only choice for broadband, spacing independent distortion testing is feedforward cancellation.

This paper presents an analytic formula for the calculation of phase shift required to cancel a signal in a feedforward measurement system based only on the power of the original and combined signals. The formula is implemented into a wideband bridge measurement system, increasing dynamic range by at least 20 dB over a system without cancellation. The cancellation formula and measurement system capability are verified through measurement of a low passive intermodulation microwave termination, with good tracking between real and predicted measurement capability.

II. FEEDFORWARD CANCELLATION

Ideally the process of cancelling a signal is a simple one, requiring only the summation of that signal with a signal of equal amplitude and opposite phase. In reality, the implementation of a cancellation system will include some degree of error in both amplitude and phase between the signals resulting in non ideal system behavior. The cancellation achievable in any system, taking into account phase and amplitude deviation, follows the well know equation for rejection [2],

$$P_o - P_c = -10 \log(\alpha^2 + 2\alpha \cos(\phi) + 1) \quad (1)$$

Where $P_o - P_c$ is the difference in amplitude (dB) of the original signal and the cancelled signal. The α term reflects the amplitude error in a multiplicative sense with $V_c = V_o \alpha$, ($\alpha \geq 0$), while ϕ represents the difference in the cancellation tone phase from 180 degrees from the original tone. A contour plot of this relationship is shown in Figure 1, clearly showing that a very small phase or amplitude imbalance results in large deviations from ideal cancellation.

While schemes such as power minimization and gradient techniques are effective at cancelling tones even under such high accuracy requirements, they can often take several iterations to reach reasonable cancellation levels [2,6]. In a measurement system, a spectrum analyzer or vector signal analyzer can easily be used to measure the power present at a single frequency. An analytic formula that could predict the needed phase shift from only an amplitude measurement would greatly reduce the number of iterations required to obtain near perfect cancellation. Such a formula can be obtained starting with the case of cancelling a single sinusoidal signal. Consider a single sinusoidal signal which is the combination of the original signal and the cancellation signal,

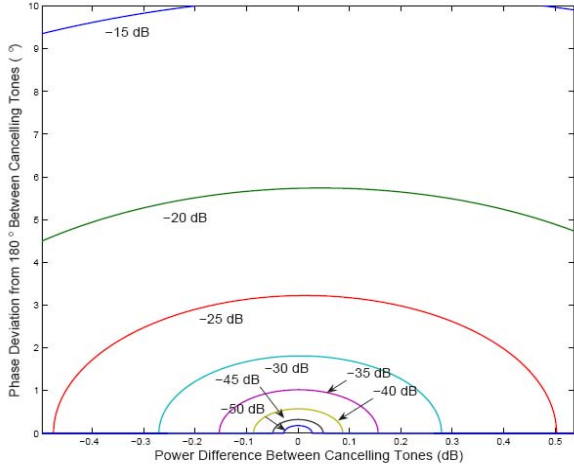

Fig. 1: Cancellation as a function of phase and amplitude error between original and cancelling tone [2].

$$\alpha \cos(\omega t + \phi_1) + \alpha \cos(\omega t + \phi_2) = \beta \cos(\omega t) \quad (2)$$

where α is the amplitude of both the original and cancellation signal, ω is the frequency of the tone, ϕ_1 is the phase of the original signal, ϕ_2 is the phase of the cancellation signal, and β is the combined signal amplitude. Since all tones exist at the same frequency, this can be rewritten as a function of only the magnitude and phase difference,

$$\cos(\phi_1) + \cos(\phi_2) = \frac{\beta}{\alpha} \quad (3)$$

and from trigonometric identities it can be shown that [4],

$$\cos(s) \cos(t) = 2 \cos\left(\frac{s+t}{2}\right) \cos\left(\frac{s-t}{2}\right). \quad (4)$$

Applying this identity gives the relation,

$$2 \cos\left(\frac{\phi_1 + \phi_2}{2}\right) \cos\left(\frac{\phi_1 - \phi_2}{2}\right) = \frac{\beta}{\alpha}. \quad (5)$$

Defining ϕ_1 as the reference phase and $\phi_1 + \phi_2$ as the phase difference ϕ , the equation becomes,

$$\cos\left(\frac{\phi}{2}\right) \cos\left(\frac{-\phi}{2}\right) = \frac{\beta}{2\alpha}. \quad (6)$$

Recognize that the second cosine term contains a $-\phi$ term, which simply represents a phase shift of 180 degrees from the phase difference term. Rewriting the formula in its final form,

$$\phi = \pi - 2 \arccos\left(\frac{\beta}{2\alpha}\right). \quad (7)$$

This formula enables the effective determination of required phase shift with extremely low error even when near 180 degrees phase shift is needed. Two caveats are contained within this equation. The first is that only the magnitude of the phase shift is known. This is easily remedied in a vector signal analyzer, where phase information at the cancellation

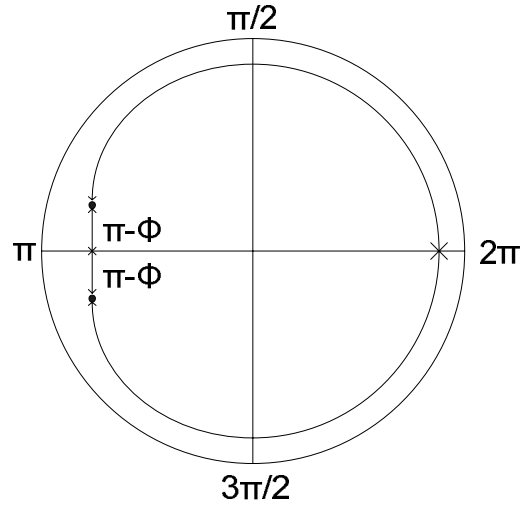

Fig. 2: Separate cancellation paths on the unit circle as a result of magnitude only measurements.

plane is available. Without this convenience, an extra iteration of the formula to correct the phase shift direction may be needed, as shown in Figure 2.

The second caveat in this formula is the assumption of equal amplitude of original and cancellation signals. Slight amplitude errors can severely degrade system performance. Cancellation degradation can be easily circumvented by pre-test calibration of various bridge branches at the cancellation reference plan or S-parameter characterization of components in the cancellation path. The error between required real phase shift and analytically predicted phase shift plotted against original tone and cancellation tone phase difference is shown in Figure 3.

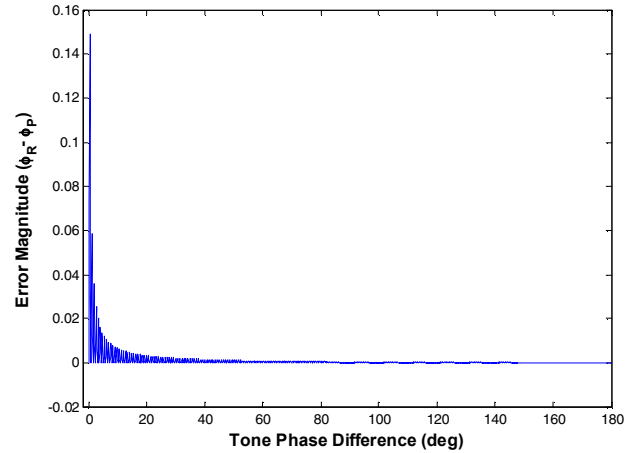

Fig. 3: Required phase shift and theoretical predicted phase shift difference versus actual tone phase separation.

Accuracy of the formula, assuming no amplitude error, is lowest when the two tones have the same phase, limited to only 35 db of cancellation. Error reduces as the phase difference between tones increases, lending itself to greatly increased accuracy upon a second application. Although the formula is only derived to cancel a single tone, its extension to multi-tone tests is not difficult. It can be applied to any

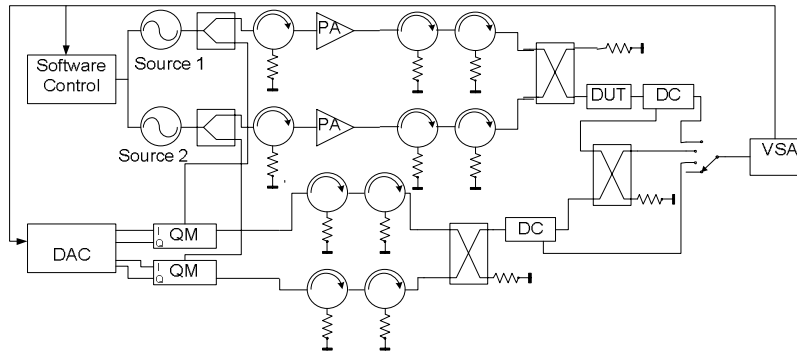

Fig. 4: High Dynamic Range Two Tone Passive Intermodulation Distortion Bridge Measurement System composed of highly linear amplifiers, RF sources, circulators, hybrid combiners, directional couplers (DC), vector modulators, and a Vector Signal Analyzer.

frequency, so long as the measurement of tone power at that frequency is still accurate.

Implementation of (7) in a real measurement system can be accomplished through the establishment of a reference cancellation plane. The reference plane can be created by measuring the probing tone power and then measuring the power from the combination of the feedforward path and DUT path signals at the bridge point. This measurement could be done once and used as a golden data set or could be tested as a characterization repeated automatically during each measurement using a standard vector signal analyzer or spectrum analyzer with probe points provided by directional couplers and switches. With use of calibration data, only a single amplitude measurement is needed to determine where the phase of various tones is on the unit circle before cancelling those tones, provided minimal amplitude error between the original signal and cancellation signal exist.

III. FEEDFORWARD MEASUREMENT SYSTEM ARCHITECTURE

Feedforward cancellation used in a measurement system is simply an application of the well known bridge method for measuring small variations in components or signals. In this case, vector modulators balance the bridge branches through the rotation of phase and amplitude through one branch. Commercial vector modulators provide up to 360 degrees phase rotation and amplitude control between 20 to 40 dB, eliminating the need for delay lines or static attenuation. Providing the initial signal content to a vector modulator as the local oscillator input allows the modulation of phase and amplitude of the original signal with only the use of a digital to analog converter applied to the I and Q inputs of the vector modulator. The vector modulator and device under test branches of the bridge will combine at a reference plane. Only the original signal will be fed forward and cancelled, allowing high dynamic range measurement of the unaffected distortion products beyond the reference plane. While conceptually simple, many practical issues arise when implementing such a system, such as DUT path linearity, cancellation path linearity, microwave radiation, and accuracy of power measurement.

Determination of a cancellation architecture starts with the choice of employing separate signal sources or feeding forward part of the original signal. This choice, while

seemingly unimportant, is paramount in a high dynamic range measurement system. Phase stability and noise addition are major issues that are unavoidable when employing separate cancellation sources. Sources with different frequency synthesizer architectures have been observed to have instantaneous phase stability that differ with time such that they are only frequency locked, not phase locked [3,7]. Random phase variations in independent fractional synthesizers are only required to have on average a particular time-varying phase relationship. This time-varying phase relationship will cause the phase relationship between the two tones to wander, such that using separate sources to provide the cancellation tones requires a constant phase control to retain cancellation [2]. Feedforward designs remove this issue as the cancellation tone is part of the original probe signal, thus inherently phase and frequency locked to the probe signal.

If separate sources are used, the danger of noise summation still exists. Although both sources may be frequency and phase locked, allowing coherent cancellation that tracks over time, noise from these sources will be independent and will sum. Noise summation detracts from the dynamic range of the system, and will ultimately limit the effectiveness a secondary source can have. Fortunately, feedforward techniques do not fall victim to this pitfall, as source noise is also fed forward and cancelled, leaving only the added noise of components between, such as the DUT, vector modulators, combiners, and cables.

The rest of the DUT path must also be distortion free within the dynamic range of the system, with the exception of the DUT itself. A general architecture for a wideband measurement system accomplishing a low distortion DUT path is shown in Figure 4. Key to this architecture is the use of a single, highly linear amplifier for each test tone and the effective backward wave isolation provided by terminated circulators. Circulators are necessary to isolate the output of the amplifier from nonlinear interaction with other stimulus through the finite isolation of the hybrid combiner. This isolation is extremely important in the cancellation branch, where reflected wave components can interact with the nonlinear junctions contained within the vector modulators. While circulators provide needed isolation, they also limit system bandwidth, and if not used carefully, produce distortion themselves. System bandwidth limitations can be

overcome by using high power switches designed for low PIM performance to switch between isolators in different bands.

Of utmost importance in any high dynamic range system is the choice of connector type employed throughout the system. According to [5], DIN and N type connectors plated with silver or tri-metal exhibit superior PIM performance over smaller counterparts such as SMA type connectors. The method of connector attachment must be chosen carefully to gain the benefits of larger contact area connectors. Solder connections are always preferable over clamped or crimped connections. Selection of hybrid combiners, directional couplers, attenuators, and cabling all follow the same connector guidelines, and should generate much less distortion than would be measurable in the system. Directional couplers allow probing in the system and dynamic characterization over power and frequency, but are not necessary if calibration is done beforehand.

IV. MEASUREMENTS

The system shown in Figure 4 was used for test of microwave chip terminations that require more than the standard dynamic range of a vector signal analyzer, which was approximately 75 dB in this system. Filtering techniques were not feasible, as the phenomenon being measured is dependent on tone spacing due to thermal heating and cooling of the termination. Tone spacing for this measurement ranged from 1 Hz to 100 Hz.

Cancellation of the probing signals and source noise extended the measurement dynamic range 20 dB or more than the dynamic range of the measurement system without cancellation. Unfortunately, the vector modulators used in this system limited the dynamic range from further increases. Generally third order distortion products decrease at a rate of three to one, so regardless of cancellation, reduction in power greatly reduces measurable distortion products. Power had to be backed off due to radiation coupling through a wideband balun on the LO input of the vector modulators, which is currently the major factor limiting performance.

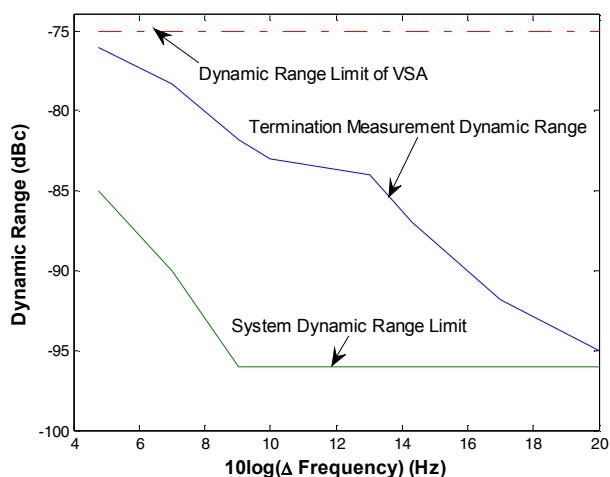

Fig. 5: System dynamic range and dynamic range used in the measurement of a tantalum nitride microwave termination's PIM over tone spacing.

Cancellation levels were approximately 25 dB over power and frequency for a single iteration, with a useable bandwidth of 300-500 MHz, limited by the power amplifiers. Dynamic range of the system was increased to approximately 95 dB even at incredibly tight tone separations of 10 Hz, as shown in Figure 5. Finite resolution in amplitude measurements was the prominent source of cancellation error, which also becomes worse as the receiver becomes more saturated. Experimentally this algorithm works more effectively at lower power, but can be reapplied for further error reduction in high power testing.

V. CONCLUSION

A high dynamic range distortion measurement system has been presented which employs an analytic model to predict the phase shift to cancel a signal at a single frequency. This model uses only knowledge of the probing signal power and the combined probe and cancellation signal power. The system extends the dynamic range of intermodulation distortion measurement to 95 dB, a 20 dB increase due to cancellation, which was verified by measuring a microwave chip termination for electro-thermal PIM versus tone spacing. Cancellation performance of the system tracks the analytic formula well, with deviation only due to measurement error in signal power from the vector signal analyzer.

VI. ACKNOWLEDGEMENT

This material is based upon work supported by the U.S. Army Research laboratory and the U.S. Army Research Office as a Multi-disciplinary University Research Initiative on Standoff Inverse Analysis and Manipulation of Electronic Systems under grant number W911NF-05-1-0337.

REFERENCES

- [1] E. Rubiola and V. Giordano, "Advanced interferometric phase and amplitude noise measurements," *Review of Scientific Instruments*, vol. 73, pp. 2445-2457, June 2002.
- [2] A. L. Walker, *Behavioral Modeling and Characterization of Nonlinear Operation in RF and Microwave Systems*, Ph.D Dissertation, North Carolina State University, Raleigh, NC, 2005.
- [3] A. Walker, M. Steer, K. Gard, "Simple, broadband relative phase measurement of intermodulation products," 65th Automated RF Techniques Group Conf. Digest, June 2005.
- [4] R.E. Moyer and F. Ayres, *Trigonometry*, McGraw-Hill, New York, 1999.
- [5] J. Henrie, A. Christianson, and W. Chappell, "Intermodulation Power Generated by Coaxial Connectors," Private Communication, 2006.
- [6] S. P. Stapleton, "Adaptive FeedForward Linearization for RF Power Amplifiers," 55th Automated Radio Frequency Testing Group Conf. Digest, vol. 37, pp. 1-7, June 2000.
- [7] A. Walker, M. B. Steer and K. Gard, "A vector intermodulation analyzer applied to behavioral modeling of nonlinear amplifiers with memory effect," *IEEE Trans. Microwave Theory and Tech.*, Vol. 54, Issue 5, May 2006, pp. 1991-1999.