

Multipoint-to-Point Lightpaths in All-Optical Networks : Dimensioning and Cost Analysis

Nizar Bouabdallah^{*¶}, Guy Pujolle[‡] and Harry Perros[¶]

[¶] Computer Science Department, NC State University
Raleigh, NC 27995-8206

^{*} INRIA, IRISA campus universitaire de beaulieu
F-35041 Rennes, France

[‡] LIP6, University of Paris 6

8 rue du Capitaine Scott, F-75015 Paris, France

Email: nizar.bouabdallah@inria.fr ; guy.pujolle@lip6.fr ; hp@csc.ncsu.edu

Abstract—In this paper, we propose and evaluate a new concept of traffic aggregation in wavelength-division multiplexing (WDM) optical networks that aims at eliminating both the bandwidth underutilization and the scalability concerns that are typical of all-optical wavelength-routed networks. Our objective is to reduce the network cost while preserving the benefits of all-optical wavelength-routed networks. Indeed, in optical networks, the bandwidth demand of a traffic stream can be much lower than the capacity of a lightpath. Higher throughput and lower cost can be achieved by efficiently grooming low-speed connections onto high-capacity lightpaths. In order to assess the efficiency of our proposal, all underlying network costs are compared. These costs include that of the transceivers required at node level as well as the number of wavelengths. Our results show that the proposed aggregation technique can significantly improve the network throughput while reducing its cost.

Index terms—Optical networking, traffic grooming, all-optical and opaque networks, network dimensioning and cost evaluation.

I. INTRODUCTION

In the current nomenclature of optical networking, a network is referred to as transparent (all-optical) when its constituent nodes are all-optical cross connects (OXC) where no conversion into the electrical domain is performed. Within transparent networks, lightpaths are routed from source to destination in the optical domain, optically bypassing the intermediate nodes. The optical signal is converted into electronics only at the source and destination nodes. In contrast, in opaque networks, lightwave channels are terminated at each node, then electronically processed, switched and reassigned to a new outgoing wavelength as needed.

In order to successfully instantiate connections, network resources (e.g., wavelengths, transceivers) have to be allocated. This issue is well known as the routing and wavelength assignment (RWA) problem. A number of RWA studies have been conducted in the optical networking domain [1]-[3]. But, most previous studies assumed that a connection requests the entire bandwidth capacity of a lightpath channel. In this study, we consider the case where a connection can request either the whole or some fraction of the lightpath capacity. This makes the problem more practical and general.

Generating connections in an all-optical wavelength-routed network involves the establishment of point-to-point (PtoP) lightpaths between every edge node pair. These lightpaths may span multiple fiber links. The all-optical

wavelength-routing approach presents two obvious advantages. The first advantage stems from the fact that the optical bypass eliminates the need for Optical-Electrical-Optical (OEO) conversion at intermediate nodes. As a result, the node cost decreases significantly, since in this case the number of required expensive high-speed electronics, laser transmitters and receivers is reduced. The second advantage is due to all-optical routing, which is transparent with regard to the bit rate and the format of the optical signal.

In spite of the aforementioned advantages, the all-optical wavelength routing approach presents two major drawbacks. The first one is related to the large number of wavelengths required within large networks. For a full connectivity, a network with N edge nodes requires $O(N^2)$ lightpaths. The second drawback is the rigid routing granularity entailed by such an approach. This granularity is large, which can lead to bandwidth waste. Indeed, the bandwidth demand of a traffic stream can be much lower than the capacity of a lightpath. Higher throughput and lower cost can be achieved by efficiently grooming low-speed connections onto high-capacity lightpaths. Typically, by allowing traffic from different nodes to share a single lightpath, the bandwidth can be utilized more efficiently.

On the other hand, an opaque network has the advantage of being able to efficiently use the link bandwidth. Nonetheless, as nodes do not have optical pass-through, this results in a maximum transceiver cost. In the long term, optical packet switching (OPS) appears as a promising solution. In fact, a major advantage of electronic packet switching is its bandwidth efficiency, relying on statistical multiplexing. Currently, there is a research effort to bring packet switching concepts into the optical domain. However, OPS is not ready yet and it is hampered by major technology limitations due to the issues related to the fine switching granularity adopted (optical packet) at high bit rate [4].

In view of this, OPS is a solution that may become feasible in the future. Meanwhile, the trend is to improve the efficiency of existing mature all-optical networks. In this regard, in our work, there has been much emphasis on circuit-switched all-optical networks, where the goal in this context is shifted more toward the improvement of optical resource usage by means of new traffic aggregation scheme, rather than toward the attempt to realize optical packet switching.

To achieve this, we propose a new solution, which combines the advantage of the optical bypass in transparent wavelength routed networks with statistical multiplexing

gain. In this technique, a lightpath, remaining entirely in the optical domain, is shared by the source node and all the intermediate nodes up to the destination. So, in essence, a single lightpath is used to establish a multipoint-to-point (MptoP) connection. We refer to this technique as the distributed aggregation scheme.

In this study, we provide typical designs of networks that function according to the distributed aggregation scheme. We consider both ring and mesh topologies. Moreover, we evaluate the network cost savings enabled by the distributed aggregation concept. To achieve this, the network cost is compared with respect to PtoP all-optical and opaque networks. These costs include that of the transceivers and cross-connect ports required at the node level, as well as the number of wavelengths. We note that in practice, the transceiver cost dominates the cost of wavelengths in a network.

The rest of the paper is organized as follows. In section II, we give a literature review and point out our position relative to previously published papers. A detailed description of our new approach is outlined in section III along with the MAC (Medium Access Control) protocol required to avoid collisions on the shared MptoP lightpaths. Moreover, the general problem statement is presented in section IV. In section V, we investigate the network architecture needed to support the traffic aggregation scheme within the optical ring topology. The network cost is then evaluated by means of a mathematical model and compared to PtoP all-optical and opaque networks. In section VI, we extend the study to the regular meshed WDM networks case. Then, in section VII, a simple provisioning algorithm, i.e., a heuristics is proposed to handle the case of arbitrary mesh topologies. In section VIII, the comparison between distributed aggregation and the existing strategies is tackled from a different perspective. We compare the blocking probability of dynamically arriving connection requests under all underlying strategies. Finally, some conclusions are drawn in section IX.

II. RELATED WORK

As explained before, both opaque and PtoP all-optical networks are no more consistent with the packet switching philosophy of the internet. In this context, two major enabling factors have been identified as crucial for the evolution process of the next-generation networks architecture: packet switching and optical transparency. The trend is therefore towards switching packets directly in the optical domain, as this can take advantage of both packet flexibility and optical transparency.

In this regard, a lot of research is currently focusing on how to implement packet switching in the optical domain. However, OPS is hampered by major technology bottlenecks, such as the lack of optical processing logic, optical memories, and cost-effective fast switching and synchronization technologies. One way to by-pass some of these technological problems is the use of optical burst switching (OBS) [5].

OBS avoids the very short switching time required by OPS. A burst is an aggregation of many packets with the same egress node, and the same class of service. Using large bursts of data, the processing on the network can be

reduced compared to OPS. However, in OBS, there is no guarantee that a burst will be successfully transmitted without being dropped by intermediate nodes due to contention of bursts going to the same outgoing port. Depending upon the nature of the transmitted data, a dropped burst may have to be retransmitted, which of course decreases the network's throughput.

OPS, and in particular OBS, is a solution that may become feasible in the future. Meanwhile, the trend is to improve the efficiency of existing mature all-optical networks. In this regard, recently, there has been much emphasis on circuit-switched all-optical networks, where the goal in this context is shifted more toward the improvement of optical resource usage by means of new traffic aggregation schemes, rather than toward the attempt to realize optical packet switching. Two promising solutions have been identified in the literature to reconcile between the optical transparency and sub-wavelength grooming concepts: multi-hop (MH) networks and super-lightpath networks.

The key idea behind MH networks is to allow electronic processing at some intermediate nodes of the all-optical circuit-switched network in order to increase its grooming capacity [6]. Accordingly, a packet may undergo electronic processing at some intermediate nodes before reaching its final destination. Hence, lightpaths can be seen as chains of physical channels through which packets are moved from a router to another toward their destinations. At intermediate nodes, the transit lightpaths are switched transparently through an OXC that does not process transit data. Instead, incoming lightpaths destined to the current node are terminated and converted to the electronic domain, so that packets can be extracted, processed, and possibly retransmitted on outgoing lightpaths, if the current node is not the final destination of the data.

The cost introduced by this electronic processing operation at the intermediate nodes is significant. However, it enables a better use of the network resources and it reduces the total network cost compared to the PtoP all-optical circuit-switched networks [6]. The main challenge with MH networks is to identify the optimal logical topology that minimizes the total network cost, while accommodating all the traffic requests. It has been demonstrated that the identification of the optimal logical topology is computationally intractable for large size networks [7]. In view of this, several heuristic approaches were proposed in the literature [6].

The second promising solution to achieve both the optical transparency and sub-wavelength grooming is super-lightpath concept [8]. This approach increases the grooming capacity of a regular PtoP all-optical circuit-switched network, as they transform the concept of the lightpath from a PtoP pipe to a point-to-multipoint (PtoMP) pipe. In other words, the source node of a super-lightpath does not limit its transmission to the end node of that lightpath; instead, it can transmit its traffic to all the intermediate nodes along the route. This allows the super-lightpath to carry multiple connections, resulting in better wavelength utilization.

The super-lightpath technique uses a simple Optical Time Division Multiplexing (OTDM) method, which permits splitting the bandwidth of a wavelength among several traffic flows. Accordingly, each bit in a given

position of the fixed-size TDM frame, called bit slot, identifies a particular subchannel. Using a bit interleaver, the transmitter multiplexes sub-channels into the frame, and transmits the resulting stream into one lightpath. With regard to reception, each intermediate node splits the transit signal, synchronizes its receiver to a particular bit slot, and only receives data in that particular sub-channel.

The super-lightpath technique presents many advantages. First, it reduces the number of transmitters per node since the same transmitter will be used to send data to more than one receiver. Moreover, it improves the lightpath utilization. The main concern with this PtoMP method is related to the limited length of the super-lightpath. Specifically, a significant portion of the passing-through optical signal is tapped at each receiving intermediate node, and therefore, due to power limitations the number of traversed nodes is limited.

III. DISTRIBUTED AGGREGATION SCHEME

The key idea underlying our proposed scheme is to allow sharing of a lightpath among several access nodes. Instead of limiting the access to the lightpath capacity at the ingress point, each node along the path can fill the lightpath on the fly according to its availability. In this case, a lightpath can be shared by multiple connections traveling towards a common destination (i.e., MptoP lightpaths). Wavelength routing is performed in a similar way as in all-optical networks, i.e. signals remain in the optical domain from end to end and are optically switched by intermediate nodes. Since the lightpath remains transparent at intermediate nodes, a MAC (Medium Access Control) protocol is required to avoid collision between transient optical packets and local ones injected into the lightpath. We have already proposed a simple MAC protocol based on void/null detection in [9]. This mechanism, which will be described next, guarantees collision free packet insertion on the transient wavelength at the add port level of an intermediate node. Briefly, this is done as follows. Each station monitors the transmission of the optical packets on the pass-through lightpath, and when it detects a big-enough gap between two successive packets, it transmits a packet from its own buffer.

A. The Distributed Aggregation Scheme : An example

To illustrate the distributed aggregation mechanism, we consider the simple three-node network example shown in Fig.1. We assume that each fiber has one wavelength and each node is equipped with a fixed transmitter and a fixed receiver. Two connection requests are to be served: (0,2)

with a bandwidth requirement equal to half of the wavelength capacity; and (1,2) with a bandwidth requirement equal to quarter of the wavelength capacity.

In the PtoP all-optical network case (Fig1.a), only the connection (0,2) will be served. The connection between node pair (1,2) will be rejected even if the wavelength between these two nodes is not being fully used. Hence, an extra wavelength between pair nodes (1,2) and a new receiver at node 2 would be required in order to satisfy all the connection requests.

However, using the distributed aggregation scheme (Fig1.b), the traffic demand could be satisfied by establishing one lightpath from node 0 to node 2. In this case, both connections will share the same lightpath. Indeed, the second connection (1,2) would be carried using the spare capacity of the existing lightpath. Note that the lightpath $0 \rightarrow 1 \rightarrow 2$ is still routed optically through node 1, thus preserving the benefit of optical bypass.

The merit of distributed aggregation is that multiple connections with fractional demands can be multiplexed onto the same lightpath. As a result, the wasted bandwidth problem associated with pure wavelength routed networks is alleviated. In addition, due to the sharing of lightpaths, the number of admissible connections in the network is increased. Furthermore, the destination node handles fewer lightpaths as connections from different nodes to the same destination are aggregated onto the same lightpath. In view of this, fewer physical components, such as wavelengths and transceivers, are used, resulting to savings on equipment. Moreover, in order to provide connections between all access node pairs using MptoP lightpaths, a total number of $O(N)$ lightpaths is required since only one lightpath per individual egress node could be sufficient. Thus, we alleviate the scalability issue encountered in classical all-optical wavelength routed networks.

B. The MAC Protocol

Let us consider J nodes placed along a unidirectional lightpath. Buffered packets at each node level are transmitted onto the lightpath towards the node where the lightpath is terminated. These packets travel along the lightpath without any electro-optic conversion at intermediate nodes.

The main issue with this scheme is collision-free packet insertion on a shared MptoP lightpath. Neither active optical devices nor electronic conversions are employed to handle the packet insertion. Instead, traffic control mechanisms are used at the electronic edge of the access nodes to avoid collisions with transit traffic.

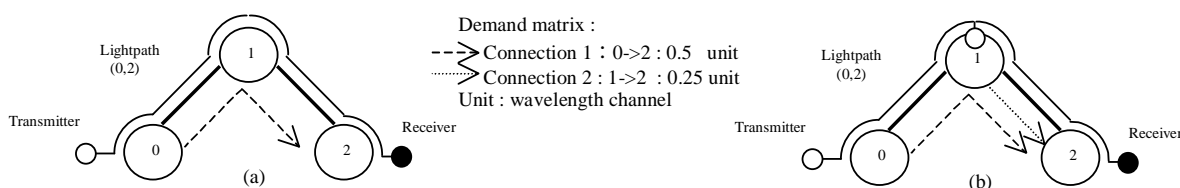

Fig. 1 A simple demonstration network. (a) All-optical Wavelength routed network. The connection request (1,2) is rejected. (b) Distributed aggregation scheme. All connection requests are satisfied.

We believe that asynchronous transmission allows for a better use of resources as opposed to synchronous transmission. Asynchronous transmission fits better the traffic flowing in high-speed networks, which is typically bursty. Authors in [10] showed the limitations of the TDMA approach due to the lack of statistical multiplexing. Hence, we focus in this paper on a contention-based media access protocol rather than on a time-sharing solution.

In a fixed-slotted system with fixed-size packets, void (i.e. slot) filling can be carried out immediately upon its detection, since the void duration is a multiple of the fixed-size packet duration. The detected void is therefore guaranteed to provide a minimum duration of one packet length. However, in non-slotted systems with variable packet length and arbitrary void duration, a collision may occur if a packet is immediately transmitted upon the detection of the beginning of a void.

To meet these requirements, each node along the shared lightpath must retain the upstream traffic flow within the optical layer while monitoring the medium activity. Specifically, as shown in Fig. 2, each node first uses an optical splitter to separate the incoming signal into two identical parts: the main transit signal and its copy used for control purposes. With regard to the control part, as in [11], low bit rate photodiodes (ph) –typically 155 MHz– are used to monitor the activity of the transit lightpath. Once a free state of the medium is detected, the MAC unit measures the size of the progressing void.

To do so, a fiber delay line (FDL) is introduced on the transit path to delay the upstream flow by one maximum frame duration augmented by the MAC processing time. The length of the FDL is slightly larger than the maximum transmission unit (MTU) size allowed within the network, in order to provide the MAC unit with sufficient time to listen and to measure the medium occupancy. The node will begin injecting a packet to fill the void only if the null period is large enough (i.e. at least equal to the size of the packet to be inserted). Undelivered data will remain buffered in the electronic memory of the node until a sufficient void space is detected. This way, collision free packet insertion on the pass-through lightpath from the add port is ensured.

It is easy to see that such an access scheme relies only on passive components (couplers, FDL, ph) with relatively low cost. The cost introduced by the MAC unit is negligible compared to the transceiver cost. However, with this basic packet insertion mechanism, head of the line blocking and fairness issues could arise. Indeed, such a transmission scheme introduces an unfair advantage to those nodes that are closer to the source node. The fairness of this scheme was examined in [12], where we proposed an additional protocol, called Traffic Control Architecture using Remote Descriptors (TCARD), that eliminates unfairness among optical nodes. In TCARD, each transmitting station is equipped with anti-tokens that prevent the station from transmitting a packet during a gap in the optical packet stream. These anti-tokens permit some of the gaps to go by unused, and therefore, they can be used by other downstream stations. The rate of generation of the anti-tokens at a station is set equal to the rate of the aggregate downstream transmission.

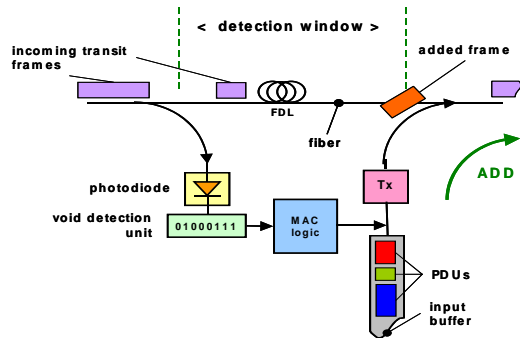

Fig. 2. Schema of the CSMA/CA based MAC.

IV. GENERAL PROBLEM STATEMENT

In this paper, we provide a cost analysis of all underlying networks. Our approach will be to propose and analyze a collection of basic ring and mesh architectures and compare them to our proposed designs, working under the distributed aggregation process. Specifically, we obtain formulae that quantitatively link network resources to traffic parameters. The costs of interest, as defined in [13], are as follows:

a) *Number of Wavelengths W* : This is the maximum number of lightpaths that goes through any link.

b) *Transceiver Cost Q* : This is the average number of transceivers per node in the network. It seems that the transceiver cost may reflect actual costs better than the number of wavelengths. The number of transceivers is defined as:

$$Q = (Tx + Rx) / 2 \quad (1)$$

where Tx (Rx) denotes the average number of transmitters (receivers) respectively per node.

c) *PortOXC Cost*: It represents the average number of OXC ports required at each node level.

The traffic distribution will be represented by a traffic matrix T , where $T(i, j)$ represents the amount of traffic between nodes i and j , expressed in lightpaths. For example, if the traffic between the node pair (i, j) is 15 Gb/s and the wavelength capacity is 10 Gb/s, then $T(i, j) = 1.5$. The networks will be compared using the costs W , Q and *PortOXC*, assuming the following static uniform traffic:

$$T(i, j) = \begin{cases} \tau & \text{if } i \neq j \\ 0 & \text{otherwise} \end{cases} \quad (2)$$

This traffic pattern requires good network connectivity, and its uniformity simplifies the analysis. It is worth noting such traffic pattern is used as an approximation of the real traffic. It is commonly used to compare networks in the theoretical literature. The following optical networks will be considered in the analysis. Later, we will provide a more detailed description of the networks and their costs.

Opaque WDM Network: This network does not have true optical nodes because lightpaths do not pass through nodes, i.e., traffic at each node is processed electronically.

PtoP All-Optical Network: Between each pair of nodes i and j , there are $\lceil T(i, j) \rceil$ lightpaths. Traffic between the

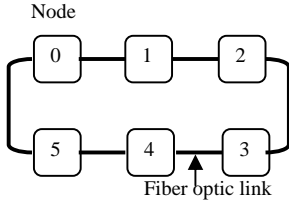

Fig. 3. An optical WDM ring.

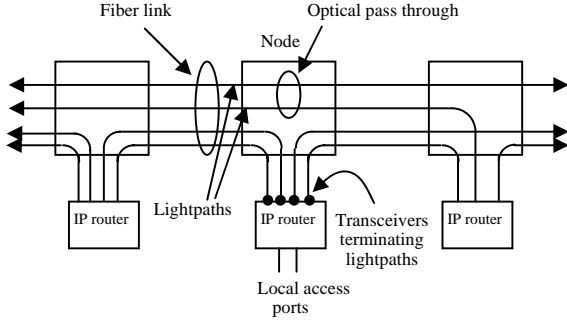

Fig. 4. A WDM ring node.

nodes is carried directly by these connecting lightpaths. This is an all-optical network since it has no electronic traffic grooming. It is therefore the opposite of the opaque WDM network, which has maximal traffic grooming capabilities. Note that it is well suited for static traffic if the traffic is high enough to fill in the lightpaths.

MptoP Optical Networks: This is an optical network, which uses the distributed aggregation scheme.

V. OPTICAL WDM RING ARCHITECTURES

A typical WDM ring network is shown in Fig. 3. It consists of N nodes labelled $0, 1, \dots, N-1$ clockwise, interconnected by fiber links. Each link carries high-rate traffic over different wavelengths. WDM ring networks are being developed as part of test-beds and commercial products, and are expected to be an integral part of telecommunication backbone networks. Although mesh topologies will be of greater importance in the future, at least in the near term, ring topologies are viable because SONET/SDH self-healing architectures are ring oriented.

A typical node in a WDM ring is shown in Fig. 4. Note that some of the lightpaths pass through the node in optical form. They carry traffic not intended for the node. The remaining lightpaths are terminated at the node by transceivers, and their traffic is converted into electronic form, and processed electronically. The electronic processing (and switching) includes systems such as SONET/SDH ADMs, IP routers, and digital crossconnect systems (DCSs) that crossconnect traffic streams. To simplify the presentation, we shall observe IP router systems at a later stage, but the very same discussion holds for the other type of electrical nodes. In Fig. 4, the IP router is shown representing all the electronic processing, and the transceivers are located at the interface of the IP router and lightpaths.

A. The Opaque WDM Ring

A special case of an optical ring network is the opaque WDM ring network shown in Fig. 5. Here, each link in the network has one-hop lightpaths on each of its wavelengths. The network is called opaque ring because lightpaths are established only between neighboring nodes. Each node has a single IP router that routes traffic from all the lightpaths.

The opaque ring has the advantage of being able to efficiently use the link bandwidth for time-varying traffic. Its disadvantage is that its nodes do not have optical pass-through, resulting in maximum transceiver cost. For instance, in a typical carrier network, each link may have 16 wavelengths, each carrying 10 Gb/s traffic data. Suppose a ring node needs to terminate only one lightpath worth of traffic. In this case, the node would ideally pass through the remaining 15 lightpaths in optical form without processing them. On the other hand, an opaque ring would require the traffic from all 16 wavelengths to be received, possibly switched through an electronic IP router, and retransmitted. This operation can have a great impact on the network cost.

Assume the opaque ring network and static uniform traffic as before. We assume that all traffic is routed along the shortest path in the ring. Then, the average number of hops, H , needed to route traffic from its source to its destination is:

$$H = \begin{cases} \frac{N+1}{4} & N \text{ odd,} \\ \frac{N+1}{4} + \frac{1}{4(N-1)} & N \text{ even.} \end{cases} \quad (3)$$

Therefore, the amount of traffic going through a link is:

$$L = \frac{H \times \text{Total traffic}}{\text{Number of links}} = \frac{H \times \sum_i \sum_j T(i, j)}{N} = \begin{cases} \frac{N^2-1}{4} \cdot \tau & N \text{ odd,} \\ \frac{N^2}{4} \cdot \tau & N \text{ even.} \end{cases}$$

In this case, as the lightpaths are unidirectional, the number of wavelengths required by each link is:

$$W = \begin{cases} \left\lceil 2 \left\lfloor \frac{N^2-1}{8} \right\rfloor \cdot \tau \right\rceil & N \text{ odd,} \\ \left\lceil 2 \left\lfloor \frac{N^2}{8} \right\rfloor \cdot \tau \right\rceil & N \text{ even.} \end{cases} \quad (4)$$

Also recall that the number of transceivers per node is:

$$Q = W = Tx = Rx \quad (5)$$

B. The PtoP All-Optical Ring

In this network $\lceil T(i, j) \rceil$ lightpaths have to be set up between each source and destination nodes. This type of network has been considered in [13], but for the case of full duplex lightpaths. Let us consider the static uniform matrix

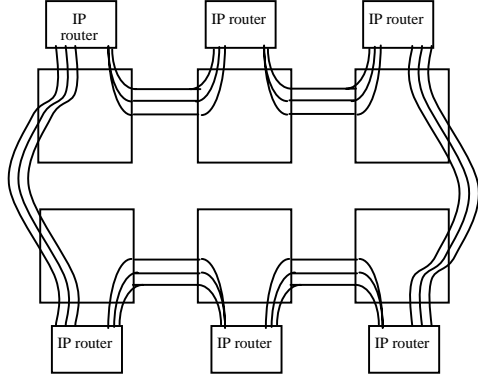

Fig. 5. An opaque WDM ring with three wavelengths.

with $\tau = 1$ and unidirectional (half duplex) lightpaths as before. Now we need to set one lightpath between each pair of nodes. The wavelength assignment will be done on a recursive basis as shown below. Let N be even.

1) Start with two nodes on the ring (see Fig. 6). The two lightpaths (one for each direction) that need to be set up will require only one wavelength since the lightpaths can use disjoint routes.

2) (Recursive step) Let k denote the number of nodes currently in the ring. While $k \leq N - 2$, add two more nodes to the ring so that they are diametrically opposite to each other, i.e., separated by the maximum number of hops (see Fig. 7). The two new nodes divide the ring in half, where each half has $k/2$ old nodes. In one half, each old node sets up two lightpaths to each new node. Therefore, each old node needs four lightpaths to connect to the new nodes. This requires, however, only two wavelengths per old node since each old node can fit its four lightpaths using the same pair of wavelengths (as the lightpaths use disjoint routes). Thus, a total of k new wavelengths are required. The old nodes in the other half of the ring can do the same thing and use the same wavelengths. Finally, the two new nodes require an additional wavelength to be connected. Thus, we need to add a total of $k + 1$ new wavelengths. So the number of wavelengths needed to do the assignment is:

$$W = 1 + 3 + 5 + \dots + N - 1 = \frac{N^2}{4}$$

For arbitrary τ the wavelength assignment can be done with

$$W = \lceil \tau \rceil \frac{N^2}{4} \quad (6)$$

wavelengths, where N is even.

When N is odd, we start the procedure above with three nodes and add two nodes each time. The number of wavelengths in this case can be calculated to be:

$$W = \lceil \tau \rceil \frac{N^2 - 1}{4} \quad (7)$$

In addition, the number of transceivers required per node is:

$$Q = \lceil \tau \rceil (N - 1) \quad (8)$$

C. The MptoP Optical Ring

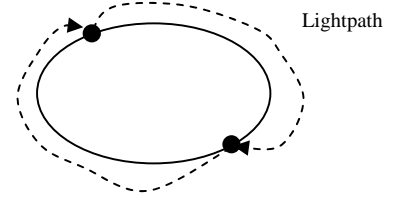

Fig. 6. Setting up two lightpaths between the first two nodes.

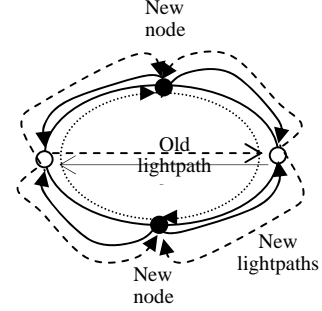

Fig. 7. Setting up lightpaths for two new nodes.

Here, we describe our proposed architecture enabling the distributed aggregation scheme. This network has a node, designated as the hub (denoted by node 0), which has lightpaths directly connecting it to all the other nodes (Fig. 8). A connection request between two ring nodes has to traverse two lightpaths before it reaches its destination. The hub node connects the ring to the backbone network.

The network can be described as a unidirectional fiber split into downstream and upstream channels spectrally disjointed (i.e. on different wavelengths). The downstream bus, initiated at the hub node, is a shared medium for reading purposes, while the upstream bus, initiated at the ring nodes, is a multiple access-writing medium. In the downstream direction, the ring is a point-to-multipoint network, and in the upstream direction it is a multipoint-to-point network that uses the distributed aggregation scheme.

Let us consider N nodes placed in the unidirectional ring, as shown in Fig. 8. Each node serves one or more access networks. Typically, most of the traffic from the access networks has its destination out of the ring network. Such a traffic, which is carried to the core via the hub node, is collectively called hubbed traffic.

With regard to the direction from the access networks to the feeder ring, the ring node plays the role of a concentrator. Buffered packets are transmitted on the upstream bus towards the hub without any electro-optic conversion at intermediate nodes. The intermediate nodes can use pass-through lightpaths to inject their local traffic towards the hub. Specifically, a lightpath remaining entirely in the optical domain is shared by a source node and all intermediate nodes up to the hub.

The hub terminates the upstream wavelengths and electronically processes the packets. According to its destination, a packet is forwarded either into the backbone network or through the downstream bus to reach the ring nodes to which it is destined. In the downstream direction, the hub maintains lightpaths to various ring nodes. Each lightpath can be shared in reception by several ring nodes. To do so, each ring node copies the downstream signal,

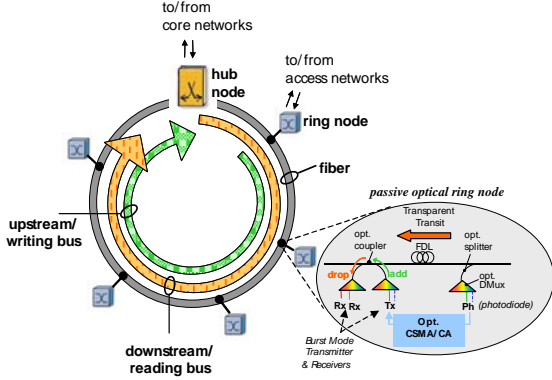

Fig. 8. Overview of MptoP ring network and node architecture.

originating from the hub, using a splitter, from which it recovers the transmitted packets. Once split, the main signal is no longer processed at the node level and it continues its path towards the other ring nodes sharing the lightpath. Each ring node terminates the copied lightpath, electronically processes the data packets and delivers them to users.

As stated before, the main issue with this scheme is the collision-free packet insertion on the shared upstream bus, which can be solved using the MAC protocol described above.

This architecture fits the hubbed traffic networks, which are often observed in access rings. The spectral separation allows the use of a simple passive structure for the optical part of ring nodes. In this context, this architecture inherits the advantages of PON technology [14]. Moreover, we preserve the optical transparency property. Thus, ring nodes will need transceivers for their local traffic only. In addition, as described above it provides a fraction of the wavelength capacity to each ring node, a single wavelength for all upstream nodes, and a single head-end receiver at the hub node. Hence, the hub transceiver needs are also reduced.

As stated before, any intermediate node i ($i = 2, \dots, N-1$) can use the traversing lightpaths to inject its local traffic intended to the hub node. If sufficient capacity exists, the ring node i traffic would be carried by the spare capacity of the pass-through lightpaths. Otherwise, the node i has to create new lightpaths to handle the remaining local traffic destined to the hub. Here, we suppose that the traffic injected by the different ring nodes is perfectly multiplexed in the upstream wavelengths. Considering the static uniform traffic with parameter τ , then the number of the upstream wavelengths is:

$$W_{up} = \lceil (N-1)^2 \tau \rceil \quad (9)$$

Likewise, the number of downstream wavelengths is:

$$W_{down} = \lceil (N-1)^2 \tau \rceil \quad (10)$$

Thus, the total number of required wavelengths is:

$$W = W_{up} + W_{down} \quad (11)$$

Let us consider ring node i ($i = 1..N-1$). Node i has to transmit $\Lambda = (N-1)\tau$ lightpaths of traffic to the hub node. The available bandwidth seen by node i on the traversing lightpaths coming from upstream nodes (i.e. nodes $1, \dots, i-1$) is:

$$Bw(i) = \lceil (i-1)\Lambda \rceil - (i-1)\Lambda$$

The required number of transmitters at node i is then:

$$Tx(i) = \lceil \Lambda - Bw(i) \rceil + \lceil Bw(i) \rceil$$

It can be demonstrated that the total number of transmitters at all ring nodes (excluding the hub node) is provided by the expression:

$$\sum_{i=1}^{N-1} Tx(i) = N + \frac{W}{2} - 2 - \sum_{i=1}^{N-2} \lceil i\Lambda \rceil - i\Lambda = 0$$

The number of required transmitters and receivers at the hub node can be given by:

$$Tx[0] = Rx[0] = W_{up} = W_{down}$$

Hence, the average number of transmitters per node is:

$$Tx = \frac{1}{N} \sum_{i=0}^{N-1} Tx(i) = 1 + \frac{W - 2 - \sum_{i=1}^{N-2} \lceil i\Lambda \rceil - i\Lambda}{N} \quad (12)$$

Similarly, we obtain the number of receivers per node

$$Rx = Tx = Q \quad (13)$$

D. Comparison

In this section, we compare the different WDM ring networks. Based upon the calculated key costs, we draw the following conclusions:

- If wavelengths are plentiful, then the MptoP ring is a good choice. It shows the lowest transceiver cost when the traffic request between every pair of nodes is fractional of the lightpath capacity. The PtoP all-optical ring is also a reasonable choice only if the traffic between each pair of nodes is high enough to fill in the entire lightpaths capacity. In other words, PtoP ring is cost-effective when the value of τ is about $\lceil \tau \rceil$. On the other side, opaque ring near always leads to the highest transceiver cost since its nodes do not have optical pass-through. Even though, we notice that opaque approach is cost-effective when τ is very small compared to the wavelength capacity.

- If wavelengths are precious, then the opaque and PtoP rings are logical choices for WDM ring networks since they use minimal wavelengths. Opaque ring always provides the most efficient use of wavelength. We point out that MptoP approach is more suitable for hubbed traffic. In this regard, the uniform traffic matrix can be seen as a worst case for MptoP rings. In addition, we recall that in our model the cost of transceivers is a dominant issue.

Fig. 9 and 10 show W and Q values, respectively for the case $N = 8$. In the figures, τ ranges from 0 to 1. Fig. 9 shows that opaque and PtoP rings have the optimal W . Fig. 10 shows that minimum Q is attained by different networks for different values of τ . For $\tau > 1/2$, the PtoP ring has the smallest Q . For $\tau \leq 1/2$, the MptoP ring has the smallest Q . Thus, for small value of τ (where traffic grooming is more interesting), the MptoP ring attains the minimum or near the minimum for both Q and W . If wavelengths are abundant, then MptoP and PtoP rings lead to the smallest transceiver cost. Note that this example shows different architectures provide better transceiver costs over different values of τ .

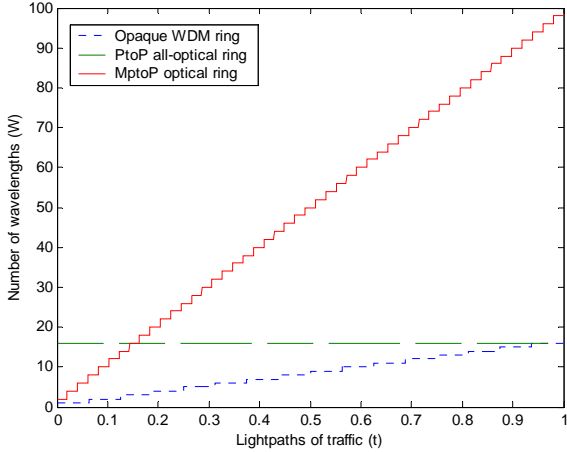

Fig. 9. The number of required wavelengths in the WDM ring networks.

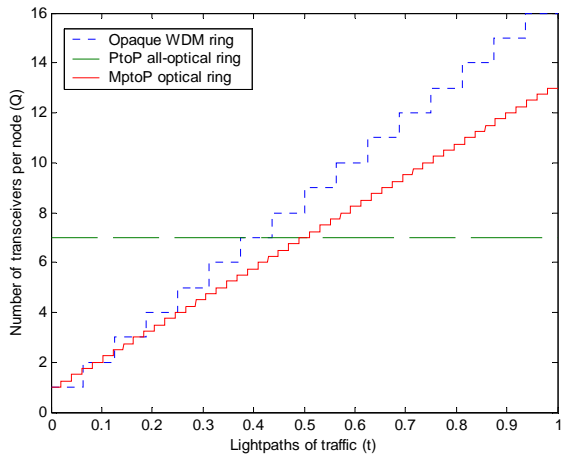

Fig. 10. The transceiver requirement per node in the WDM ring networks.

VI. WDM MESH NETWORKS ARCHITECTURES

This section can be seen as an extension of the previous study to the case of mesh networks. To carry connection requests in such a WDM network, lightpath connections may be established between pairs of nodes. Two important functionalities must be supported by the WDM network nodes: one is wavelength routing and the other is traffic grooming. Fig. 11 depicts a sample node architecture that can be employed in a WDM optical network. The node architecture comprises two components: the wavelength selective device and the access station (e.g. IP router). While the wavelength selective device performs wavelength routing, the access station performs local traffic adding/dropping and low-speed traffic-aggregation functionalities.

Bear in mind that we aim at dimensioning the optical WDM mesh network so as to serve all traffic requests between any pair of optical nodes. This is achieved by evaluating the OXC and IP router dimensions as well as the number of wavelengths. Each port of the electrical IP router is connected to the OXC port via an internal wavelength. All traffic between nodes is carried over the WDM links. A lightpath is established between nodes by setting up the OXCs along the route between nodes. Each

lightpath needs a dedicated OXC port when traversing an intermediate node. In addition, a transceiver pair is required at the ingress and egress nodes of the lightpath. Moreover, in the distributed aggregation case, each intermediate node along the path using a pass-through lightpath to transmit its traffic also needs a transmitter. In fact, the access station of a node can be either the origin of a lightpath or an intermediate node using an already established lightpath. In the latter case, the injected traffic by an intermediate node should have the same destination as that of the traversing lightpath.

Mesh topologies can be broadly classified into two categories: arbitrary and regular. Nodal connectivity patterns in regular topologies are very systematic and well defined, which simplifies routing and management operations as well as theoretical network studies. Regular topologies are widely used to compare different network designs in the literature. Suitable regular topologies include the Shufflenet [15], the de Bruijn Graph [16], the Hypercube [17], the Manhattan Street Network (MSN) [18], and the Kautz Graph [19]. Each of these architectures bases its merits on optical infrastructure. In this paper, the MSN is selected as the exemplar architecture. Nevertheless, the techniques adopted are sufficiently general and similar results can be obtained for the other architectures. MSN is chosen because it is one of the most popular architectures.

The MSN, Fig. 12, is a member of a class of multiply connected, regular, mesh-configured networks. The proposal name MSN considered unidirectional links, so that two links arrive at and depart from each node. It can be observed that the topology is made of a number of horizontal (rows) and vertical (columns) rings. Logically,

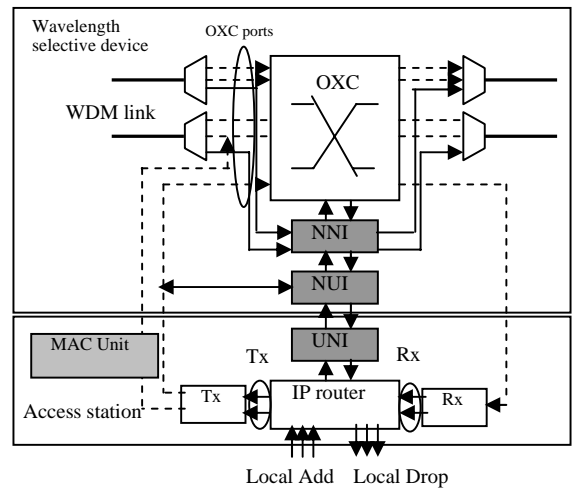

Fig. 11. Optical node architecture.

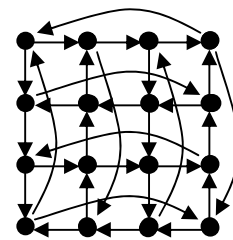

Fig. 12. 4 × 4 MSN.

the links form a grid on the surface of a torus, with links in adjacent rows or columns traveling in opposite directions.

We assume the following network characteristics:

-The meshed topology is formed by unidirectional horizontal and vertical rings.

-A node always transmits data on the horizontal ring if the destination node does not belong to the same vertical ring.

-A shortest path routing algorithm is used to route the lightpaths over the physical topology. Based on the aforementioned conditions, the route between each node pair is thus unique.

-Each node contains a selective wavelength device, i.e. an OXC, that routes and manipulates the lightpaths as desired.

Consider an $N \times N$ (square) MSN topology, and identify nodes with a pair of integers specifying their position in the grid, measured by a row and a column number. Node (i, j) (row i , column j , with $i, j = 0, \dots, N-1$) always transmits on the horizontal ring i if the destination node does not belong to the same vertical ring j . Node (i, j) always receives data from the vertical ring j if the source node does not belong to the same horizontal ring i . Note that at every node (i, j) , the optical signal arriving on the horizontal ring i is demultiplexed in order to separate lightpaths. Some of the optical channels are switched to the vertical ring j . The remaining lightpaths instead continue their journey along the horizontal ring i .

Assuming all the traffic is routed along the shortest path in the MSN network, the average number of hops H needed to route traffic from its source to its destination is:

$$H = \frac{N^2}{N+1} \quad (14)$$

The number of physical hops traversed by a lightpath is important for several reasons: it affects the number of required wavelengths and impacts on the dimensioning of the selective wavelength devices. Recall that each lightpath needs a dedicated OXC port when traversing an intermediate node along the path (including the source and destination nodes). Because of the cyclic structure of the MSN and uniform static matrix, any node can be considered to be in the center of the network and needs the same number of OXC ports. The number of OXC ports is simply:

$$\text{PortOXC} = \text{pass through lightpaths} + \text{received lightpaths} + \text{emitted lightpaths}$$

Note that this parameter is not considered in the opaque case since there is no wavelength-switching device in such a network. In the remainder of this paper, we will consider an arbitrary node (i, j) since all the network nodes exhibit the same behaviour.

A. Opaque Mesh Networks

As explained before, each link in the network carries one-hop lightpath on each of its wavelengths. The lightpaths are established only between neighboring nodes. Considering the opaque MSN and static uniform traffic as before, each link in the network carry the same amount of traffic. Therefore, the amount of traffic going through each

link is:

$$L = \frac{H \times \text{Total traffic}}{\text{Number of links}} = \frac{H \times \sum_i \sum_j T(i, j)}{2N^2} = \frac{N^2(N-1)\tau}{2}$$

Hence, the number of wavelengths traversing each link is:

$$W = \left\lceil \frac{N^2(N-1)\tau}{2} \right\rceil \quad (15)$$

As two links arrive at and depart from each node, the number of transmitters and receivers per node is equal to:

$$Q = Tx = Rx = 2W = 2 \left\lceil \frac{N^2(N-1)\tau}{2} \right\rceil \quad (16)$$

B. PtoP All-Optical Mesh Networks

In this network, $\lceil \tau \rceil$ lightpaths have to be set up between each source and destination nodes. Due to the symmetrical property of the unidirectional MSN conjugated with the uniform static matrix and the deterministic routing, each link of the network is traversed by the same number of lightpaths. So the number of wavelengths needed to do the assignment is:

$$\begin{aligned} W &= \frac{H \times \text{Total number of lightpaths}}{\text{Number of links}} \\ &= \frac{H \times \sum_i \sum_j \lceil T(i, j) \rceil}{2N^2} = \frac{N^2(N-1)}{2} \lceil \tau \rceil \end{aligned} \quad (17)$$

On the other side, the number of transmitters and receivers required per node is given by:

$$Q = Tx = Rx = (N^2 - 1) \lceil \tau \rceil \quad (18)$$

Since, two links arrive at and depart from each node, the number of pass-through lightpaths traversing each node is equal to $2W - Rx$. The number of OXC ports per node is then:

$$\text{PortOXC} = 2W + Tx = [N^2(N-1) + (N^2 - 1)] \lceil \tau \rceil \quad (19)$$

C. MptoP Optical Mesh Networks

In this network, a lightpath can be shared by multiple connections traveling towards a common destination. So, instead of limiting access to lightpath capacity at the ingress point, each node along the path can instantaneously fill in the optical resource according to its availability. Remember that node (i, j) always transmits on the horizontal ring i , and receives on the vertical ring j . Besides, we use the shortest path routing strategy. Thus, the route between each node pair is unique.

The node (i, j) emits traffic towards $N^2 - 1$ nodes gathered on N vertical rings (including the vertical ring that node (i, j) belongs, i.e. column j). As stated earlier, a node (i, j) can use a pass-through lightpath, coming from the nodes of the same horizontal ring i , to inject its local traffic intended to the egress node of that lightpath. If sufficient capacity exists, the node (i, j) traffic would be carried by the spare capacity of the pass-through lightpath.

Otherwise, the node (i, j) has to create new lightpaths to handle the remaining local traffic going to the same destination. The number of required transmitters at node (i, j) can be calculated recursively as follows:

1) First, let us consider the vertical ring V_{N-1} situated at $N-1$ hops from node (i, j) . The node (i, j) is the initiator of the lightpaths going towards the N nodes of V_{N-1} . So, node (i, j) needs

$$Tx(N-1) = N \lceil \tau \rceil$$

transmitters to forward its traffic to the N nodes of V_{N-1} .

2) Let us consider now, the vertical ring V_{N-2} . Node $(i, (j+N-1) \bmod N)$ is the initiator of the N lightpaths to V_{N-2} since it is the farthest node to the column V_{N-2} . Node (i, j) tries first to use the available bandwidth on each of the N transit lightpaths. If the spare capacity on each lightpath is insufficient (i.e. smaller than τ), node (i, j) has to create new lightpaths to handle the remaining traffic. Thus, the number of required transmitters can be given by:

$$Tx(N-2) = \left(\lceil \tau - (\lceil \tau \rceil - \tau) \rceil + 1 \lfloor \lceil \tau \rceil - \tau > 0 \rfloor \right) N$$

3) Let us consider the general case, the vertical ring V_k ($k=1..N-1$) (i.e. the vertical ring situated at k hops from node (i, j)). Node $(i, (j+k+1) \bmod N)$ is the initiator of the N lightpaths to V_k since it is the farthest node to the column V_k . The number of required transmitters at node (i, j) is:

$$Tx(k) = \left(\lceil \tau - (\lceil (N-k-1)\tau \rceil - (N-k-1)\tau) \rceil + 1 \lfloor \lceil (N-k-1)\tau \rceil - (N-k-1)\tau > 0 \rfloor \right) N$$

4) Let us consider the particular case of the vertical ring V_0 that belongs to the node (i, j) . Node $(i, (j+1) \bmod N)$ is the initiator of the $N-1$ lightpaths to V_0 (excluding node (i, j)). Similarly, the number of needed transmitters can be derived as follows:

$$Tx(0) = \left(\lceil \tau - (\lceil (N-1)\tau \rceil - (N-1)\tau) \rceil + 1 \lfloor \lceil (N-1)\tau \rceil - (N-1)\tau > 0 \rfloor \right) (N-1)$$

Finally, the number of transmitters needed at node (i, j) can be written as:

$$Tx = \sum_{k=0}^{N-1} Tx(k) = \left(N \sum_{k=0}^{N-2} \left(\lceil \tau - (\lceil k\tau \rceil - k\tau) \rceil + 1 \lfloor \lceil k\tau \rceil - k\tau > 0 \rfloor \right) + \left(\lceil \tau - (\lceil (N-1)\tau \rceil - (N-1)\tau) \rceil + 1 \lfloor \lceil (N-1)\tau \rceil - (N-1)\tau > 0 \rfloor \right) \right) (N-1) \quad (20)$$

On the other side, node (i, j) receives traffic, on the vertical ring j , coming from N horizontal rings (including the horizontal ring it belongs). The number of required receivers at each node can be easily derived

$$Rx = (N-1) \lceil N\tau \rceil + \lceil (N-1)\tau \rceil \quad (21)$$

Hence, the number of transceivers per node is:

$$Q = (Tx + Rx) / 2 \quad (22)$$

Due to the symmetrical property of the unidirectional MSN and the uniform static matrix adopted, all the unidirectional links of the horizontal rings are traversed by the same number of lightpaths. In the same way, all the

unidirectional links of the vertical rings require the same number of wavelengths in order to carry all the connection requests. Let us consider the unidirectional horizontal link L_i binding node (i, j) to node $(i, (j+1) \bmod N)$. The number of wavelengths traversing L_i can be determined recursively as follows:

1) First, let us consider the vertical ring V_{N-1} situated at $N-1$ hops from node (i, j) . The node (i, j) is the initiator of the lightpaths going towards the N nodes of V_{N-1} . So, node (i, j) needs

$$W(N-1) = N \lceil \tau \rceil$$

wavelengths, traversing L_i , to forward its traffic to all the nodes of V_{N-1} . The remaining nodes of the horizontal ring i will not use the link L_i in order to reach the nodes of V_{N-1} .

2) Let us consider now, the vertical ring V_k ($k=1..N-1$). $N-k$ nodes will use the link L_i to forward their traffic to V_k . So, the number of additional wavelengths traversing L_i to reach the nodes of V_k is:

$$W(k) = N \lceil (N-k)\tau \rceil$$

Finally, the number of required wavelengths at each unidirectional horizontal link is given by:

$$W_{hor} = N \sum_{i=1}^{N-1} \lceil i\tau \rceil \quad (23)$$

On the other side, each vertical ring j behaves as a PtoP all-optical unidirectional ring where $\lceil N\tau \rceil$ lightpaths are required between each pair of nodes of the ring. The average hop number per lightpath in a unidirectional ring with N nodes is $h = N/2$. So, the number of wavelengths on each vertical link is given by:

$$W_{ver} = \frac{h \times \text{Total number of lightpaths}}{\text{number of links}} = \frac{N(N-1)}{2} \lceil N\tau \rceil \quad (24)$$

Thus, the number of wavelengths required in the network is:

$$W = \text{Max}(W_{hor}, W_{ver}) \quad (25)$$

Two links arrive at and depart from each node. So, the number of pass-through lightpaths bypassing each node is equal to $W_{hor} + W_{ver} - Rx$. In addition, the number of emitted lightpaths by each node can be given by:

$$\text{Emitted lightpaths} = \left(N \sum_{k=0}^{N-2} \left(\lceil \tau - (\lceil k\tau \rceil - k\tau) \rceil + 1 \lfloor \lceil k\tau \rceil - k\tau > 0 \rfloor \right) + \left(\lceil \tau - (\lceil (N-1)\tau \rceil - (N-1)\tau) \rceil + 1 \lfloor \lceil (N-1)\tau \rceil - (N-1)\tau > 0 \rfloor \right) \right) (N-1)$$

The number of OXC ports per node is then:

$$\text{PortOXC} = W_{hor} + W_{ver} + \text{emitted lightpaths} \quad (26)$$

D. Comparison

In this section, we will compare the WDM mesh networks from the previous section. Briefly speaking, one can draw the following conclusions:

- If wavelengths are plentiful then the MptoP strategy is the best choice since it has the lowest transceiver cost. The PtoP all-optical strategy is also a good choice only if the traffic between each pair of nodes is high enough to fill in the entire capacity of lightpaths. On the other side, opaque

strategy always leads to the highest transceiver cost since its nodes do not have optical pass-through.

- If wavelengths are precious, then opaque and MptoP strategies are sensible choices for WDM mesh networks since they use minimal wavelengths. The opaque network always provides the most efficient use of wavelengths. MptoP network requires slightly more wavelengths but it potentially reduces the transceiver cost. PtoP network is the least effective especially when only a portion of the lightpaths capacity is used.

- The dimensioning of the selective wavelength devices (i.e. number of OXC ports) shows that the MptoP strategy allows a great savings on OXC ports over the PtoP strategy mainly when the traffic between each pair of nodes requires a fraction of the wavelength capacity.

Fig. 13, 14 and 15 show W , Q and $PortOXC$ values, respectively for the case $N = 8$ (i.e. the network comprises 64 nodes). In the figures τ ranges from 0 to 3. Fig. 13 shows that opaque and MptoP strategies have the optimal W . Fig. 14 shows that minimum transceivers cost is always attained by MptoP and PtoP networks. For small to moderate value of τ (which is where traffic grooming is more interesting), the MptoP network attains the minimum or near the minimum for both Q and W . In fact its improvement in Q over the opaque MSN can be significant. For example for $\tau = 1.5$, the MptoP MSN has a Q that is 80% smaller than the one for the opaque MSN. In addition, in this case, the MptoP MSN has a W that is 30% smaller than the one for the PtoP MSN. In this regard the MptoP MSN can be seen as a mixture of two extreme cases (PtoP and opaque networks) providing a trade-off between number of wavelengths and transceiver cost. Later we shall focus on the comparison between MptoP and PtoP strategies.

As multiple connections traveling from different nodes to the same destination could be aggregated on the same lightpath with MptoP approach, the destination node will receive less lightpaths. Consequently, the number of required receivers as well as wavelengths to handle all the traffic requests is reduced as depicted in Fig. 13. In this case, more than 55% of receiver savings can be achieved. Moreover, the MptoP strategy provides more than 30% reduction in average wavelength requirements. Since W is reduced in MptoP networks, the number of OXC ports is also reduced. The OXC port gain hence recorded can reach 60% as shown in Fig. 15.

In summary, MptoP MSN almost always has the smallest transceiver cost and leads to an efficient use of the wavelength resources. This architecture combines the merits of optical pass-through, leading to a great savings on the transceiver cost, and statistical multiplexing gain allowing efficient use of the wavelengths. Note that PtoP MSN is also effective when τ approaches $\lceil \tau \rceil$.

VII. HEURISTIC APPROACH

A. Heuristics

In the previous section, we used regular topologies as an illustration where it was possible to obtain explicit formula using the analytical methodology. In [20], we used

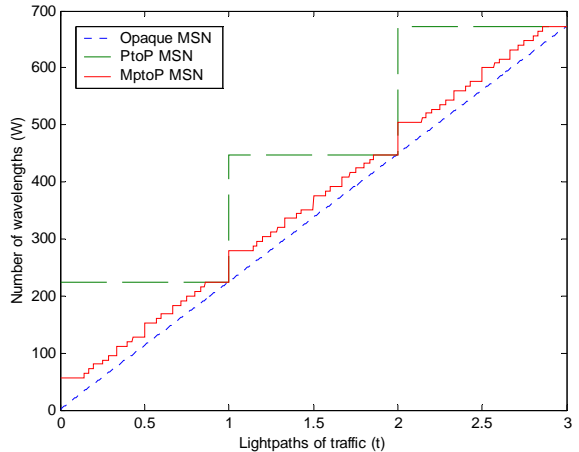

Fig. 13. The number of required wavelengths in the MSN network.

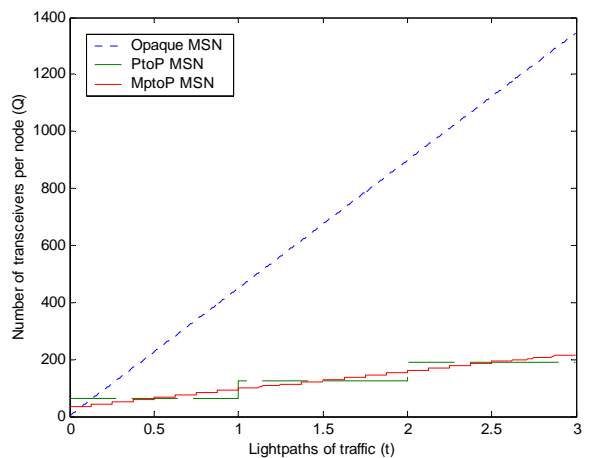

Fig. 14. The transceiver requirement per node in the MSN network.

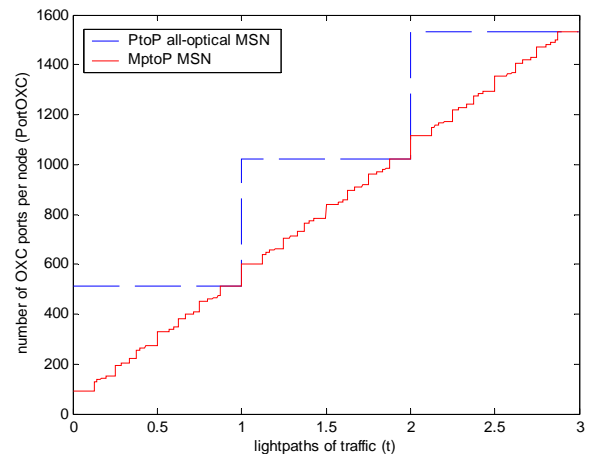

Fig. 15. The OXC port requirement per node in the MSN network.

a small arbitrary connected network as an illustration where it was possible to obtain results using the Integer Linear Programming (ILP) methodology. Nonetheless, in order to achieve the same study for large and arbitrary connected networks, we will use a heuristic approach. Here, we aim at dimensioning the optical US backbone (Fig. 16), under different strategies. The network topology consists of 29 nodes and 43 links. The network planning

has been achieved after the logical process shown below. The input of the analysis is:

- 1) The physical network topology.
- 2) The traffic matrix, which is uniform static matrix.
- 3) The adopted routing scheme, which is the shortest path algorithm in our case.
- 4) The adopted wavelength assignment approach, which is the first fit (FF) strategy in our work.

The network dimensioning is achieved by evaluating the OXC and IP router dimensions by means of the heuristic algorithm used to map the different lightpaths needed to forward all the traffic requests within the network. We omit, here, the number of wavelengths since we consider that the transceiver cost dominates the overall network cost. When dealing with opaque or PtoP strategies, the routing algorithm is simply applied to the traffic matrix to map all the required lightpaths. In this case, we deal with exact (optimal) dimensioning results. However, when the MptoP strategy is considered, we will propose a new heuristic algorithm, called *Maximizing Traffic Aggregation (MTA)*, in order to plan the MptoP lightpaths. Then the number of OXC ports, transmitters and receivers, gets determined. Thus, the obtained result can be seen as an upper bound of the optimal network cost. In this regard, we think that the shortest path routing strategy is not the optimal algorithm for MptoP networks, notably when the traffic exchanged between nodes is small compared with wavelength capacity.

Let $T(s,d)$ denote the aggregate traffic between node pair s and d , which has not been yet carried. As explained before, $T(s,d)$ can be a fraction of the lightpath capacity. In our study, we suppose that $T(s,d) \in [0,1]$, so at most one lightpath between every node pair (s,d) is required to carry all the traffic requests. Let $H(s,d)$ denote the hop distance on physical topology between node pair (s,d) .

The MTA algorithm attempts to establish lightpaths between source-destination pairs between which there is any traffic and with the highest $H(s,d)$ values. The connection request between s and d will be carried over the new established lightpath. Afterwards, the algorithm will try to carry connections, as much as possible, originating from intermediate nodes and traveling to the same destination d , based on the currently available capacity of the lightpath (s,d) . This heuristic tries to establish lightpaths between the farthest node pair in an attempt to allow the virtual topology collecting the maximum potential traffic at the intermediate nodes. The pseudo-code for this heuristics is presented hereafter:

Step 1: Construct virtual topology:

1.1: Sort all the node pairs (s,d) (where $T(s,d) \neq 0$) according to the hop distance $H(s,d)$ and insert them into a list L in descending order.

1.2: Setup the lightpath between the first node pair (s',d') using the first-fit wavelength assignment and the shortest-path routing, let $T(s',d') = 0$.

1.3: Sort all the node pairs (i,d') (where $T(i,d') \neq 0$ and i is an intermediate node traversed by the lightpath (s',d')) according to the hop distance $H(i,d')$ and insert

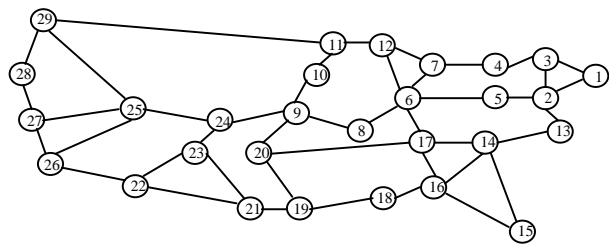

Fig. 16. The US optical backbone.

them into a list L' in descending order.

1.4: Try to setup the connection between the first node pair (i',d') using the lightpath (s',d') , subject to the current available bandwidth on lightpath (s',d') . If it fails, delete (i',d') from L' ; otherwise, let $T(i',d') = 0$, update the available bandwidth of the lightpath (s',d') and go to Step 1.3 until L' becomes empty.

1.5: Go to Step 1.1 until L becomes empty.

Step 2: Route the low-speed connections over the virtual topology constructed in Step 1.

2.1: Satisfy all the connection requests between the end nodes of the selected lightpaths, and update the virtual topology network status.

2.2: Route the remaining connection requests based on the current virtual topology network status, in the descending order of the connections' hop distance.

B. Heuristic Results and Comparison

Fig. 17 reports the transceiver requirement per node under the different strategies. In all the remaining figures, τ ranges from 0 to 1. As expected, the opaque network has the highest transceiver cost since its nodes do not have optical pass-through. Fig. 17 illustrates the improvement in transceiver requirement achieved by PtoP and MptoP strategies. Besides, the MptoP approach reduces drastically the transceiver cost over the PtoP approach when $\tau \leq 1/2$. This result is obvious since the distributed aggregation scheme allows the aggregation in the same lightpath of multiple connections traveling to a common destination. Thus, each node in the network has to terminate less lightpaths. Fig. 19 highlights the significant reduction of the number of lightpaths that should be managed when MptoP strategy is enabled. These results show how the distributed aggregation scheme relieves the scalability issue encountered with the PtoP all-optical networks.

As the number of lightpaths can be reduced to more than the half with MptoP strategy over the PtoP one, the number of OXC ports is also reduced. Beyond 50% of OXC ports saving could be achieved as depicted in Fig. 18. This gain is less important than the one obtained when dealing with lightpaths since the number of OXC ports depends not only on the number of established lightpaths but also on the average number of hops per lightpath. Indeed, the average hops number per lightpath is 3,58 in the PtoP case, whereas it is over 4 in average in the other case. We notice also that heuristics shows that when $\tau \geq 1/2$ MptoP and PtoP approaches achieve the same results. Indeed, in this range of τ , the PtoP approach is a sensible choice. In addition, we underline that the PtoP approach can be seen as a

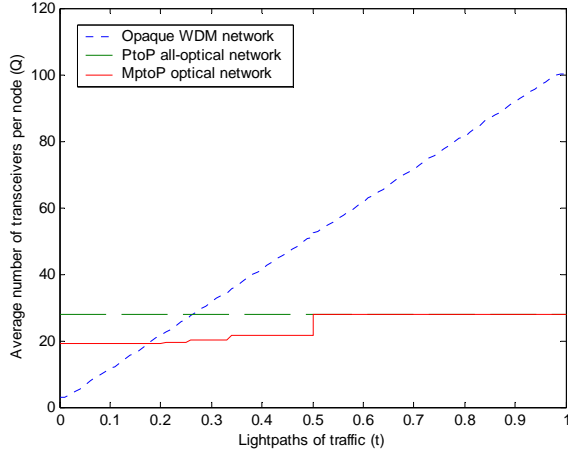

Fig. 17. The transceiver requirement per node in the US backbone.

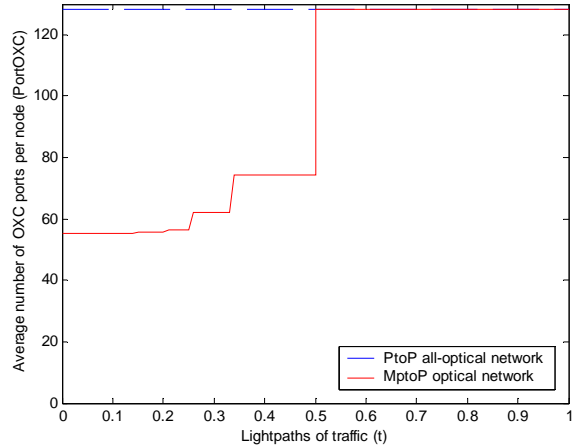

Fig. 18. The OXC port requirement per node in the US backbone.

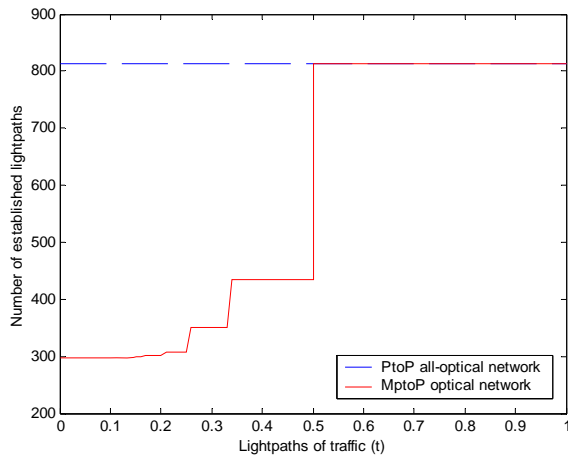

Fig. 19. The number of established lightpaths in the US backbone.

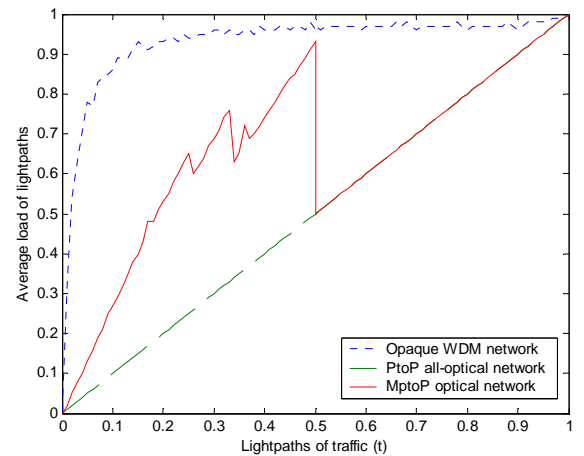

Fig. 20. The average wavelength utilisation in the US backbone.

particular case of MptoP one.

Finally, it is meaningful to compare the lightpath load among different cases (Fig.20). As expected, opaque and MptoP outperform the PtoP case. Moreover, MptoP performs slightly worse than opaque network. This result is obvious since opaque networks have the maximal grooming capability. In the PtoP case, the average load of a lightpath is very poor. The efficiency of such a strategy is possible only when there is enough traffic between pair nodes to fill in the entire capacity of wavelengths. This result emphasizes the resources under-utilisation aforementioned problem. Distributed aggregation scheme alleviates this issue, while the average load of a lightpath is near always over 50% in this case.

Although it may be possible to improve the MTA heuristic slightly by using adaptive routing algorithm for instance, these results illustrate that a significant improvement in both wavelength utilization and transceiver cost is possible with the distributed aggregation scheme. Synthetically and as previously seen with theoretical study, MptoP approach always shows the smallest transceiver cost and leads to an efficient use of the wavelength resources.

VIII. BLOCKING PROBABILITY COMPARISON

In this section, we evaluate the blocking probability

when using all underlying approaches. In addition to PtoP all-optical and opaque networks, we compare our MptoP solution to MH networks. Recall that MH networks can be seen as a hybrid solution between PtoP all-optical and opaque networks. To evaluate the gain introduced by our MptoP scheme over the MH networks, we use the heuristic proposed in [6]. Accordingly, we developed a new discrete-event simulation tool to calculate the blocking probability of dynamically arriving connection requests, under different strategies (PtoP all-optical networks, opaque networks, MH networks, and MptoP networks).

The following assumptions were made in our simulations: 1) the US backbone shown in Fig. 16 is used; 2) Each link in the network represents two fibers that are used to communicate in opposite directions. Each fiber carries 32 wavelengths; 3) Each node is equipped with 20 transceivers and 40 OXC interfaces; 4) The shortest path adaptive routing is used; 4) The first fit (FF) wavelength assignment approach is adopted; 5) Connection requests arrive at each ingress node following the Poisson distribution, and the holding time of each request is exponentially distributed. The total traffic load offered to the network by each node is $\rho = \lambda / \mu$, where λ and μ are the arrival and departure rates at each ingress node, respectively; 6) The destination node of each arriving connection is randomly chosen among the $N-1$ remaining

edge nodes of the network; 6) The bandwidth requirement of each connection request $T(s,d)$ is randomly chosen in the interval $[0,1]$, so at most one lightpath is needed to carry any traffic request. We note that, in our simulations, we do not allow the traffic from the same connection to be bifurcated among multiple lightpaths. Finally, each value of the blocking probability has been calculated over multiple simulations to achieve very narrow 97.5% confidence intervals.

In our simulations, each arriving connection tries first to use the lightpaths already established. If the available bandwidth of the existing lightpaths is not sufficient, the connection will try to establish new lightpaths subject to transceiver, OXC port and wavelength constraints. Specifically, when the MptoP case is considered, the ingress node s of an arriving connection request with destination d , looks first for a pass-through lightpath traveling toward the same egress node d which has sufficient available bandwidth. Otherwise, node s tries to establish a new lightpath subject to resource availability. If there are not enough resources to satisfy the connection request, it is simply blocked. In the same way, when MH approach is adopted, the source node s first tries to find an available route through the existing lightpaths. In this case, the connection may span multiple lightpaths before reaching its destination. If such route is not available, the connection tries to establish the missing lightpaths (end-to-end lightpath, or missing segments along the route) to reach its destination.

Figure 21 plots different blocking probabilities as a function of the network load ρ . We observe that the opaque strategy always leads to the maximum blocking probability. This is mainly due to the lack of available transceivers. Indeed, the total network capacity (in terms of transceiver equipments) is quickly exhausted, since the nodes do not permit transit connections to pass through optically. The PtoP all-optical circuit-switched strategy alleviates slightly this problem due to the optical transparency. Even though, the blocking probability remains relatively high due to the great number of P-to-P lightpaths that are required in this case. These lightpaths require a large number of OXC interfaces and wavelengths.

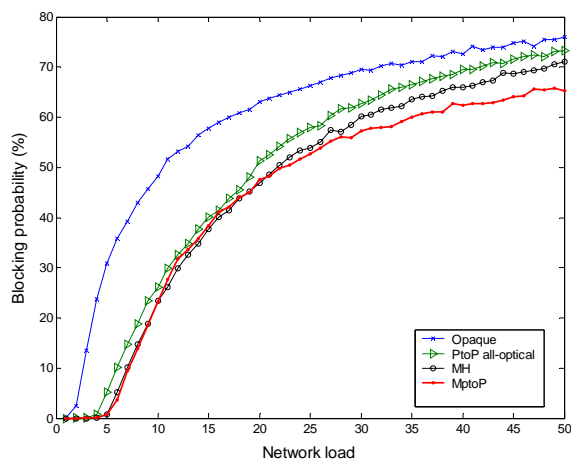

Fig. 21. Blocking probability evolution with the network load.

The MH and MptoP schemes reduce significantly the blocking probability since they alleviate the scalability issue of the PtoP all-optical networks by increasing their grooming capacity.

In addition, the MptoP scheme outperforms the MH scheme, since it requires less transceivers and OXC interfaces. Indeed, the MptoP scheme improves the PtoP all-optical circuit-switched network grooming capacity while conserving its entire transparency as opposed to the MH approach, where electronic grooming is needed at some network nodes. This active electronic processing operation enables an MH network to save in components over PtoP all-optical and opaque networks, but requires additional equipment, such as OXC interfaces and transceivers, when compared to the passive MptoP insertion. In addition, the MptoP scheme outperforms the MH scheme, since it requires less transceivers and OXC interfaces. Indeed, the MptoP scheme improves the PtoP all-optical circuit-switched network grooming capacity while conserving its entire transparency as opposed to the MH approach, where electronic grooming is needed at some network nodes. This active electronic processing operation enables an MH network to save in components over PtoP all-optical and opaque networks, but requires additional equipment, such as OXC interfaces and transceivers, when compared to the passive MptoP insertion.

Figure 22 plots the blocking probability as a function of the bandwidth requirement $T(s,d)$ of each connection request. In this case, we consider a uniform traffic matrix, i.e., $T(s,d) = \tau \forall s$ and d , where τ ranges from 0 to 1, and $\rho = 10$. This figure illustrates the general trade-off among the different strategies. According to the value of τ , we get different optimal solutions. At one extreme, when each node transmits close to the wavelength capacity to each other node, the PtoP all-optical circuit-switched approach is the best solution as the network is already well utilized without grooming. At the other extreme, when the total demand from each node is a small fraction of the wavelength capacity, opaque strategy stands out as the best solution due to its grooming capability. In most cases,

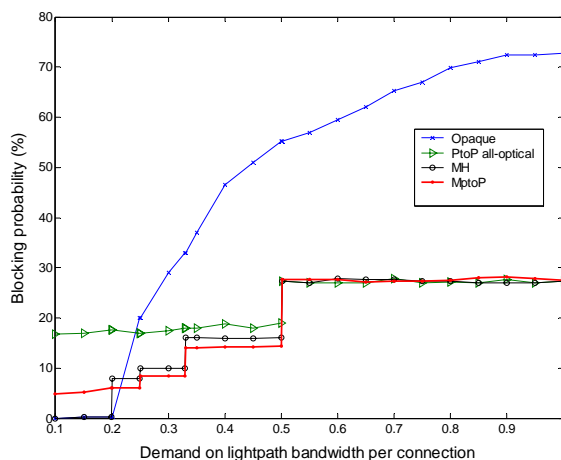

Fig. 22. Blocking probability evolution with the bandwidth requirement per connection.

when the demand is moderate to normal, MH and MptoP schemes generally present the best solutions, with an advantage to the MptoP scheme. We note that MH, MptoP and PtoP all-optical strategies achieve almost the same results when $\tau > 1/2$. This is due to the fact that we do not allow traffic belonging to the same connection request to be bifurcated among multiple lightpaths. In doing so, grooming multiple connections on the same lightpath is no more possible when $\tau > 1/2$.

IX. CONCLUSION

We have proposed a distributed aggregation approach in all-optical wavelength routed networks, relying on multipoint-to-point lightpath concept. This approach combines the merits of both the optical bypass of all-optical wavelength routing and the multiplexing gain of sub-wavelength routing. In order to assess the efficiency of our proposal, all underlying network costs were compared. Theoretical study and heuristic approach showed that our proposal always enables the smallest transceiver cost and leads to an efficient use of the wavelength resources. Distributed aggregation reduces the wasted bandwidth problem and alleviates the scalability issues encountered in all-optical wavelength routed networks while preserving the benefits of optical bypass.

REFERENCES

- [1] I. Chlamtac, A. Faragó, and T. Zhang, "Lightpath (wavelength) routing in large WDM networks", *IEEE J. Select. Areas Commun.*, vol. 14, pp. 909–913, June 1996.
- [2] D. Banerjee and B. Mukherjee, "Wavelength-routed optical networks: Linear formulation, resource budgeting tradeoffs, and a reconfiguration study", *IEEE/ACM Trans. Networking*, vol. 8, pp. 598–607, Oct. 2000.
- [3] D. Banerjee and B. Mukherjee, "A practical approach for routing and wavelength assignment in large wavelength-routed optical networks", *IEEE J. Select. Areas Commun.*, vol. 14, pp. 903–908, June 1996.
- [4] Mike J. O' Mahony et al., "The Application of Optical Packet Switching in Future Communication networks", *IEEE Commun. Mag.*, pp. 128–135, March 2001.
- [5] T. Battistilli and H. Perros, "An introduction to optical burst switching", *IEEE Commun. Mag.*, Vol. 41, no. 8, pp. S10–S15, August 2003.
- [6] K. Zhu, and B. Mukherjee, "Traffic Grooming in an Optical WDM Mesh Network", *IEEE J. Select. Areas Commun.*, VOL. 20, pp. 122–133, January 2002.
- [7] B. Mukherjee, *Optical Communication Networks*. New York: Mc-Graw-Hill, 1997.
- [8] M. Mellia, E. Leonardi, M. Feletig, R. Gaudino, and F. Neri, "Exploiting OTDM technology in WDM networks", in *Proc. IEEE INFOCOM' 2002*, pp. 1822–183, New York, USA, June 2002.
- [9] N. Bouabdallah et al., "Matching fairness and performance by preventive traffic control in optical multiple access networks", *Proc. of OptiComm '2003*, Dallas, October 2003.
- [10] G. Kramer, B. Mukherjee, and G. Pesavento, "Ethernet PON (ePON): Design and Analysis of an Optical Access Network", *Phot. Net. Commun.*, Vol. 3, no. 3, pp. 307–319, July 2001.
- [11] R. Gaudino et al., "RINGO: a WDM Ring Optical Packet Network Demonstrator", *Proc. of ECOC '01*, Amsterdam, Netherlands, Vol. 4, pp. 620–621, September 2001.
- [12] N. Bouabdallah, A. L. Beylot, E. Dotaro, and G. Pujolle, "Resolving the Fairness Issue in Bus-Based Optical Access Networks", *IEEE J. Select. Areas Commun.*, vol. 23, no. 8, August 2005, pp. 1444–1457.
- [13] O. Gerstel and R. Ramaswami, "Cost effective traffic grooming in WDM rings", *Proc. of IEEE Infocom '1998*, vol.1, pp. 69–77, April 1998.
- [14] G. Kramer, and G. Pesavento, "Ethernet Passive Optical Network (EPON): Building a next-Generation Optical Access Network", *IEEE Commun. Mag.*, pp. 66–73, February 2002.
- [15] M. G. Hluchyj and M. J. Karol, "Shufflenet: An application of generalized perfect shuffles to multihop lightwave networks," *J. Lightwave Technol.*, vol. 9, pp. 1386–1397, Oct. 1991.
- [16] K. N. Sivarajan and R. Ramaswami, "Lightwave networks based on de Bruijn graphs," *IEEE/ACM Trans. Networking*, vol. 2, pp. 70–79, Feb. 1994.
- [17] I. Chlamtac, A. Ganz, and G. Karmi, "Lightnets: Topologies for highspeed optical networks," *J. Lightwave Technol.*, vol. 11, pp. 951–961, May/June 1993.
- [18] N. F. Maxemchuk, "Routing in the Manhattan Street Network," *IEEE Trans. Commun.*, vol. Com-35, pp. 503–512, May 1987.
- [19] C. P. Ravikumar, T. Rai, and V. Verma, "Kautz graphs as attractive logical topologies in multihop lightwave networks," *Comput. Commun.*, vol. 20, pp. 1259–1269, 1997.
- [20] N. Bouabdallah, E. Dotaro, N. LeSauze, L. Ciavaglia, and G. Pujolle, "Distributed aggregation in all-optical wavelength routed networks", *Proc. of IEEE ICC '2004*, Paris, France, June 2004.