

Integrating Linear Design and Concurrent Engineering Design into Engineering Design Graphics Courses Through an Individual Furniture Design Project and a LEGO® Group Project

Theodore J. Branoff¹

Abstract – Design activities are an important part of an engineering student’s experience. The problem that many engineering programs face is where and how to integrate a design experience into the engineering curriculum. This paper outlines two types of design projects that can be completed within a single engineering graphics course. The first is a furniture design project which can be implemented using a linear design process. Students design a piece of furniture out of a 8-1/2” X 11” piece of plywood following the stages of Problem Identification, Ideation, Refinement, Analysis, Decision, Documentation, and Implementation. The second project is a group project using LEGO® kits. Students model each piece within the CAD software and create a rendered assembly of the kit. The remainder of the project can be structured so students follow a concurrent engineering design process while accessing a common database for their files. The presentation can be set up as if the students are marketing a new product line by showing off their new designs and giving examples of how children might play with the new designs.

Keywords: engineering design graphics, concurrent engineering design, linear design, LEGO® projects, furniture projects.

INTRODUCTION

A concern that engineering and design graphics faculty have is when to incorporate engineering design into the curriculum. Some feel it should occur early on in an introductory course [Bailey, Szabo & Sabers, 2]. Others feel design activities should fall within a capstone design course [McKenzie, Trevisan, Davis & Beyerlein, 15]. Still others integrate design across multiple semesters [Bertozzi, Herbert, Rought & Staniunas, 6]. Engineering design activities are also conducted in a wide range of courses. Across the country, engineering design is integrated into design graphics courses [Barr, Krueger & Aanstoos, 4; Branoff, Hartman & Wiebe, 8; Branoff, Hartman & Wiebe, 9; Kelley, 11; Kelley, 12; Verma, 18], engineering core courses [Libii, 14], and senior design courses [McKenzie, Trevisan, Davis & Beyerlein, 15].

In addition to these concerns, faculty must also select an engineering design model for students to follow. Some advocate a linear approach where students define a problem, brainstorm ideas, refine solutions, conduct analyses, decide on a solution, and then implement the solution [Bailey, Szabo & Sabers, 2; Verma, 18]. With the increased use of constraint-based modelers in industry, many feel it is important for students to follow a concurrent engineering design model [Bertozzi, Herbert, Rought & Staniunas, 6; Branoff, Hartman & Wiebe, 8; Kelley, 11; Kelley & Miller, 13]. Some say that there is no one correct way to integrate design into engineering courses. The important thing is that students learn how to solve practical problems and create functional products [Libii, 14].

¹ NC State University, P.O. Box 7801, Raleigh, NC 27695-7801, ted_branoff@ncsu.edu

No matter which type of design process is selected, it is clear that engineering graphics are a key component. In concurrent engineering design, the 3D CAD database is the central element in the whole process. It can be argued that an introductory engineering graphics course is an excellent place to introduce students to design processes.

LINEAR DESIGN PROCESSES

There are many different linear design process models. Rembold, Nnaji & Storr [16] advocate a process which includes: recognition of need, problem identification, generation or synthesis, analysis and optimization, evaluation, production and marketing, and presentation (Figure 1). Earle’s model [10] includes the action stages of identify, ideate, refine, analyze, decide, and implement (Figure 2). These models reflect traditional engineering design moving from one stage to the next. Each stage has typically represented a department or area within a company.

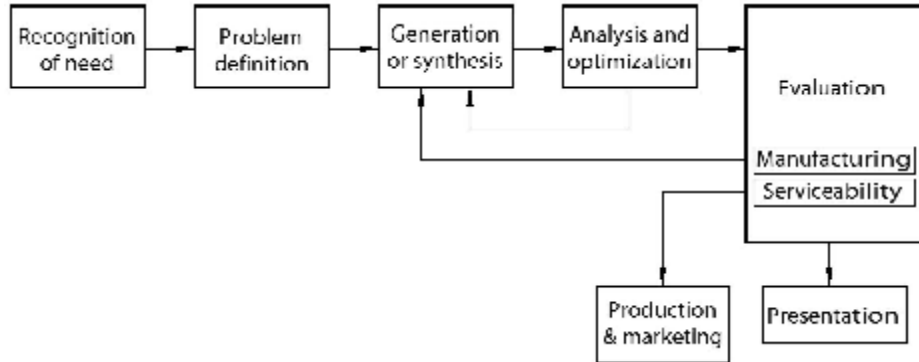

Figure 1. Rembold, Nnaji & Storr Model for the Design Process [16].

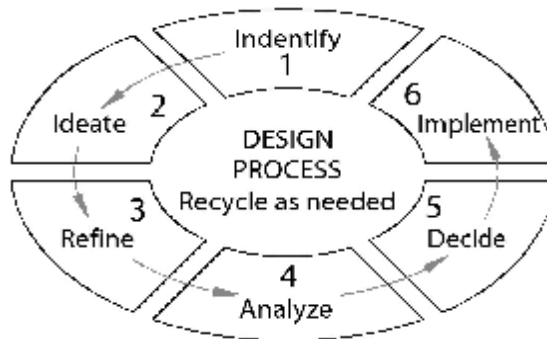

Figure 2. Earle Model for the Design Process [10].

FURNITURE DESIGN PROJECT

One way to introduce students to the linear design process is by using a simple furniture design project in an engineering graphics course [Smith, 17]. This type of project can be implemented at the beginning of the semester after students have had some introduction to basic sketching skills (multiviews and pictorials). The linear design process works well for this type of project since students can progress from one stage to the next. Using Earle’s model for engineering design [10] and Smith’s table design project [17] as a guide, the project can be arranged to meet the following goals:

1. Give a deeper appreciation of the linear engineering design process;
2. Develop multiview and pictorial sketching skills;
3. Reinforce the concepts of 2D & 3D geometry, dimensioning, and working drawings;

4. Develop a further understanding of the CAD software; and
5. Practice presentation skills.

Stage 1: Problem Identification

Design a piece of furniture from a single 4' X 8' sheet of plywood or similar material that will meet the following design parameters:

- *the piece of furniture should be of appropriate grade, type and thickness for its specified use;*
- *the design must minimize waste (calculate and report waste total);*
- *specify the finish (paint, stain, varnish, etc.);*
- *the piece of furniture should be dimensionally appropriate for the use specified (research standard dimensions for furniture of this type);*
- *the piece of furniture should be capable of supporting the amount of weight appropriate to its specified use;*
- *the total cost of all materials required to build the piece of furniture, including finish and hardware, must not exceed \$100.00 (students will "cost out" the final design at a local builders' supply store or using online resources).*

Stage 2: Ideation (Brainstorming)

Make engineering/technical sketches of at least (6) possible designs that may meet the design parameters defined in the Problem Identification stage.

It is critical that students have some type of introduction to sketching before assigning this activity. For this stage, students are encouraged to use pictorial sketches to represent their designs in one view. Figure 3 is an example of a student's initial design concepts. Even when assigning this stage near the beginning of the semester, students are still able to do a fairly good job communicating their design ideas.

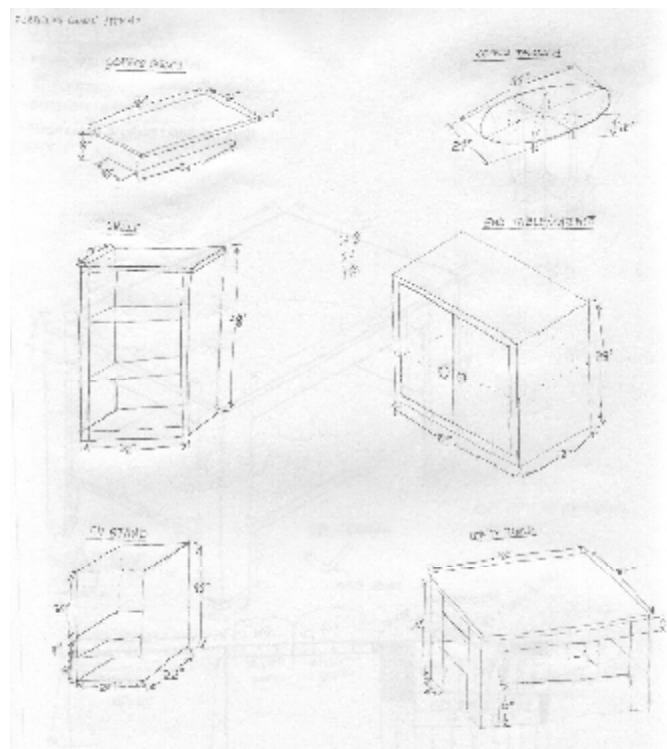

Figure 3. Example of Ideation Sketches.

Stage 3: Refine/Analyze

Analyze and critique all of the ideas generated during the Ideation step. Following this analysis, select the three ideas that, in your opinion, best meet the design parameters defined in **Stage 1**. For this stage, add more detail to the sketches of each design solution. Include a sketched layout of the 4' X 8' sheet of material and how each piece in the furniture design will be cut from it.

Stage 4: Decision

Create a decision matrix and assign a rating for how well each of the three designs meets the design parameters defined in **Stage 1**. Add other design parameters that you think are appropriate. After the ratings have been assigned for each design, the highest rated design will be carried forward to **Stage 5**.

For this stage, students can use a spreadsheet program to generate the decision matrix or instructors can have them sketch them. Table 1 illustrates a decision matrix with some suggested design parameters.

Table 1. Example of a Decision Matrix.

Design 1	Design 2	Design 3	Design Parameters
5	5	4	Waste is minimized
5	5	5	Best use of \$100.00
4	5	4	Structural Integrity
3	4	5	Aesthetic Appeal
4	4	5	Quality of Finish
5	3	4	Ease of Construction
2	3	5	My Roommate's Opinion
28	29	32	Total

Stage 5: Documentation

Create engineering/technical sketches of both the assembly and details of your furniture design. The assembly sketch should include an exploded pictorial of the table and a bill of materials. The bill of materials should detail the cost of each item and the total cost of the project. The detail sketches should include all dimensions and notes necessary to fabricate the piece of furniture. These sketches should be of the sort that a technician could use to create finished engineering/technical drawings of the furniture. Visit builders' supply store or use online resources.

As with the decision matrix, instructors may elect to have students sketch the bill of materials or to have them produce it with a spreadsheet. Table 2 is an example of a bill of materials for a table design. When completing the documentation stage, it is critical to give students examples of the kinds of sketches they should be producing. This is especially true if the topic of dimensioning has not yet been covered in the engineering graphics course. Examples of an exploded assembly sketch and detail drawing sketches are shown in Figure 4.

Table 2. Example of a Student's Bill of Materials.

ITEM	PART NAME	QTY	ITEM COST	TOTAL COST
1	TOP	1	4' X 8' X 3/4" OAK PLYWOOD (7 PLY) \$49.17	
2	SHELF	1		
3	WIDE LEG	4		
4	NARROW LEG	4		
5	LONG SIDE BRACE	2		
6	SHORT SIDE BRACE	2		
7	LONG SUPPORT	8		
8	SHORT SUPPORT	8		
9	FOOT	4		
10	#10 X 1-1/2" WOOD SCREWS -100	1		
11	1-1/2" FINISH NAILS (1lb. box)	1	\$1.81	\$1.81
	MINWAX SEMI-GLOSS POLYURETHANE	2 qts.	\$8.54	\$17.08
	TOTAL			\$72.41

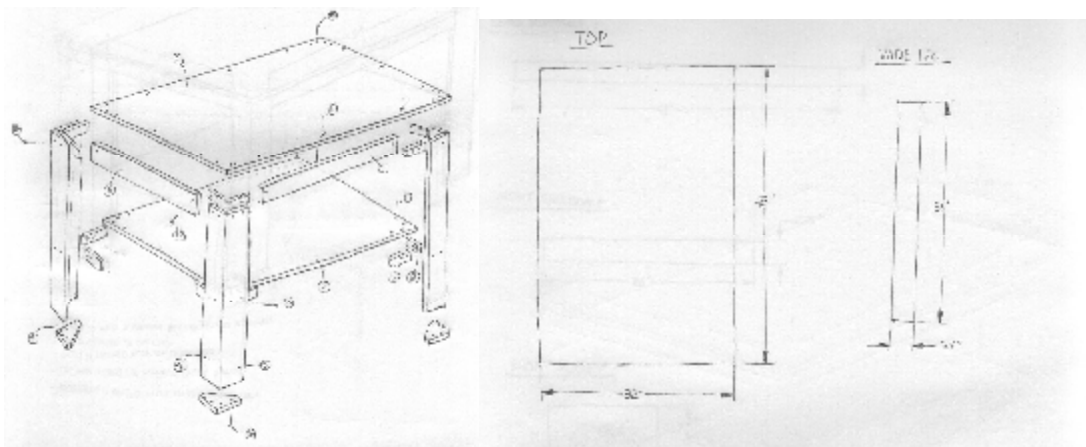

Figure 4. Example of Assembly and Detail Drawing Sketches.

Stage 6: Implementation

Create solid models (using the CAD software) of all parts and create an assembly of the final piece of furniture. Render your assembly as close to the final object as possible.

The implementation stage typically involves manufacturing a product. This is not practical in an introductory engineering graphics course. Modeling and rendering an assembly of a design is much more feasible. Since this project involves parts that are cut from a single sheet of 4' X 8' piece of material, creating CAD models of the parts are not too difficult for students. Each model typically involves creating a single extruded feature. Hinges, handles, or other purchased parts may create unique challenges for students if they specify them in their design. Students also have to be introduced to more advanced features in the CAD software such as creating assemblies and rendering. Examples of furniture projects created by students in an introductory engineering graphics course are shown in Figure 5.



Figure 5. Examples of Furniture Designs.

Stage 7: Presentation

Each student will have 3-5 minutes to present their final design to the class. The presentation may involve PowerPoint slides, color print-outs, sketches, scale models, etc. The class will vote on the top designs.

CONCURRENT ENGINEERING DESIGN PROCESSES

As constraint-based modeling programs became more prevalent, many companies switched from linear to concurrent engineering design [Kelley, 11]. Concurrent engineering design puts the 3D database at the center of the design process. This type of design model allows most employees earlier access to the 3D database than with linear design. Figures 6 & 7 illustrate two common models for concurrent engineering design [Barr & Juricic, 3; Bertoline & Wiebe, 5]. Most companies using constraint-based CAD and concurrent engineering design also implement some type of product data management (PLM) system to manage access to files [Kelley & Miller, 13].

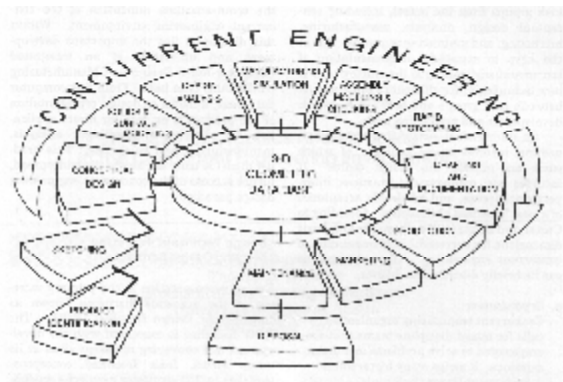

Figure 6. Barr & Juricic Model for Concurrent Engineering Design [3].

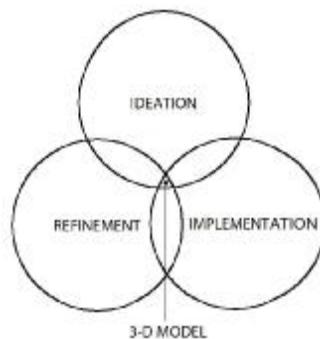

Figure 7. Beroline & Wiebe Model for Concurrent Engineering Design [5].

LEGO® GROUP PROJECT

In order for students to experience concurrent engineering design, they must work within a group. Group projects can be set up to promote teamwork and individual responsibility. Although a PLM system is not required to implement a concurrent engineering design project, a constraint-based tool within a group setting gives students a feel for the importance of planning early in the design process [Kelley, 12].

One type of project that can be implemented within this setting is a LEGO® group project [Branoff, 7]. This project can be used to practice sketching and documentation skills learned during the semester, but more importantly, it gives students a feel for what it is like working within a concurrent engineering design team. The project can be divided into the following steps:

- Step 1** Divide into groups. Select a LEGO® assembly. Categorize the pieces by level of difficulty for sketching and modeling. Divide the pieces equitably among the group members.
- Step 2** Create multiview sketches of each part.
- Step 3** Add dimensions to the sketches by reverse engineering the parts (Figure 8).
- Step 4** Create solid models of each part using the constraint-based CAD software.
- Step 5** Create an assembly in the constraint-based CAD software.
- Step 6** Design new pieces that fit within the theme of the LEGO® assembly.
- Step 7** Create new assemblies in the constraint-based CAD software (Figure 9).
- Step 8** Create detail drawings of the new pieces within the CAD software.
- Step 9** Put together a document that includes all of the above items (Figure 10).
- Step 10** Prepare a PowerPoint presentation to introduce the class to your new designs. Describe the new features and how they fit into the existing product line. Give examples of story lines kids might come up with as they play with the new designs.

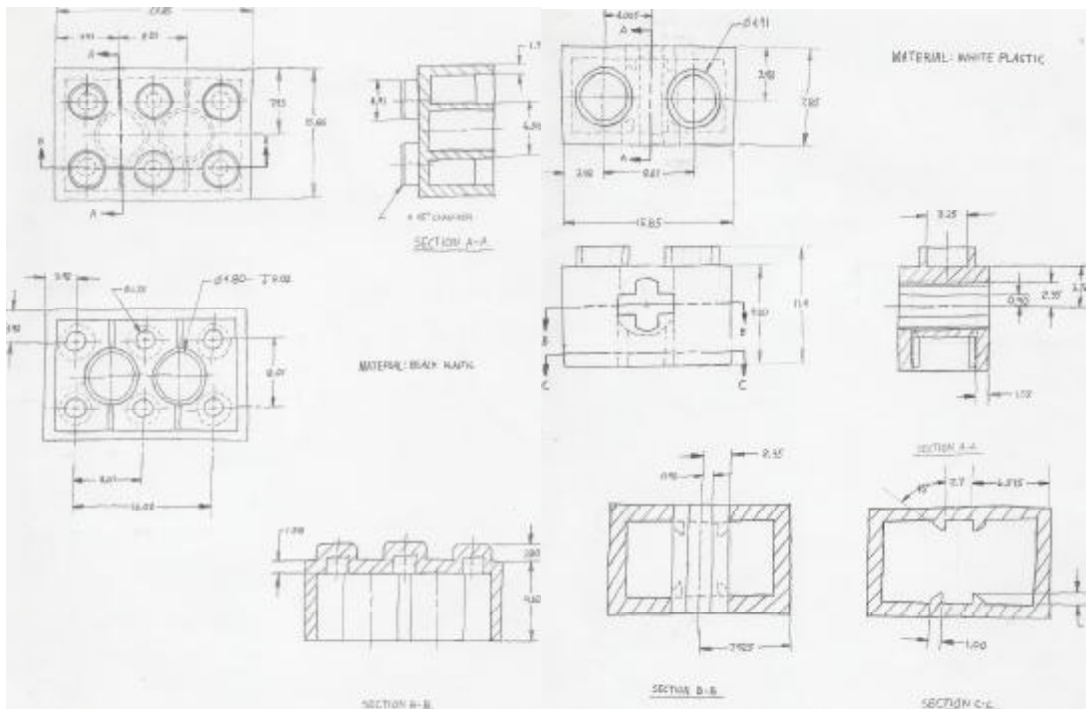

Figure 8. Multiview Sketches of the LEGO® Pieces.



Figure 9. Examples of New Assemblies.



Figure 10. Example of a Document from the Presentation.

Students must meet on a regular basis to discuss the progress of the group and plan modeling strategies for the parts. The benefits of a constraint-based system are usually realized when the group is creating the assemblies. They see the importance of planning for the location of part origins, coming up with standards for LEGO® dimensions, and file/data management. Steps 9 & 10 give the students an opportunity to practice writing and presentation skills. It also is a showcase for their creativity.

CONCLUSION

Engineering programs need to give more emphasis to graphics throughout the curriculum, and students should be taught to use a wider range of graphical elements to better communicate design ideas [Ault, 1; Barr, Krueger & Aanstoos, 4]. They also need to be introduced to engineering design early in their programs so they can make better connections with their core engineering courses. The furniture design project and the LEGO® group project are two examples where a constraint-based modeler can be used in an introductory engineering graphics course to help make these connections. The projects also further develop important skills that students need to be successful in their programs.

REFERENCES

- [1] Ault, H. K. (2002). Engineering design graphics as a communications tool for mechanical design: A broader view. *Engineering Design Graphics Journal*, 66(3), 12-19.
- [2] Bailey, R., Szabo, Z., & Sabers, D. (2004). Assessing student learning about engineering design in project-based courses. *Proceedings of the 2004 Annual Meeting of the American Society for Engineering Education, Salt Lake City, Utah, June 20-23, 2004*.
- [3] Barr, R. E., Juricic, D. & Krueger, T. J. (1994). The role of graphics and modeling in the concurrent engineering environment. *Engineering Design Graphics Journal*, 58(3), 12-21.
- [4] Barr, R. E., Krueger, T. J., & Aanstoos, T. A. (2004). Results of an EDG student outcomes survey. *Proceedings of the 2004 Annual Meeting of the American Society for Engineering Education, Salt Lake City, Utah, June 20-23, 2004*.
- [5] Bertoline, G. R. & Wiebe, E. N. (2005). *Fundamentals of graphics communication*. (4th ed.). Boston: McGraw-Hill.
- [6] Bertozzi, N., Herbert, C., Rought, J., & Staniunas, C. (2004). Implementation of a three-semester concurrent engineering design sequence for lower-division engineering students. *Proceedings of the 2004 Annual Midyear Meeting of the Engineering Design Graphics Division of the American Society for Engineering Education, Williamsburg, VA., November 21-23, 2004*.
- [7] Branoff, T. J. (2004). Using LEGO[®] Group Projects to Increase Student Understanding of Constraint-Based Solid Modeling and Other Engineering Graphics Concepts. *Proceedings of the 2004 Annual Meeting of the Southeast Section of the American Society for Engineering Education, Auburn, Alabama, April 4-6, 2004*.
- [8] Branoff, T. J., Hartman, N. W., & Wiebe, E. N. (2002). Constraint-based, three-dimensional modeling in an introductory engineering graphics course: Re-examining the curriculum. *Engineering Design Graphics Journal*, 66(1), 5-10.
- [9] Branoff, T. J., Hartman, N. W., & Wiebe, E. N. (2003). Constraint-based, solid modeling: What do employers want our students to know? *Engineering Design Graphics Journal*, 67(1), 6-11.
- [10] Earle, J. H. (1999). *Engineering design graphics*. (9th ed.). Reading, MA: Addison-Wesley.
- [11] Kelley, D. S. (2001). Group design problems in engineering design graphics. *Engineering Design Graphics Journal*, 65(3), 6-12.
- [12] Kelley, D. S. (2004). Assessing the utilization of virtual LEGO[®] blocks within a group design project. *Engineering Design Graphics Journal*, 68(2), 26-31.
- [13] Kelley, D. S. & Miller, C. L. (2003). Building a foundation for a PLM centered engineering graphics curriculum. *Engineering Design Graphics Journal*, 67(2), 6-11.
- [14] Libii, J. N. (2004). Integration of design in the engineering core: Teaching engineering science courses with design in mind. *Proceedings of the 2004 Annual Meeting of the American Society for Engineering Education, Salt Lake City, Utah, June 20-23, 2004*.
- [15] McKenzie, L. J., Trevisan, M. S., Davis, D. C., & Beyerlein, S. W. (2004). Capstone design courses and assessment: A national study. *Proceedings of the 2004 Annual Meeting of the American Society for Engineering Education, Salt Lake City, Utah, June 20-23, 2004*.
- [16] Rembold, U. Nnaji, B. O. & Storr, A. (1993). *Computer integrated manufacturing and engineering*. Workingham, England: Addison-Wesley.
- [17] Smith, D. W. (2002). Introducing EDG students to the design process. *Proceedings of the 2002 Annual Midyear Meeting of the Engineering Design Graphics Division of the American Society for Engineering Education, Berkeley, CA., January 6-8, 2002, 1-6*.

- [18] Verma, S. (2004). The Design Challenge Program in support of the engineering design graphics course. *Proceedings of the 2004 Annual Meeting of the American Society for Engineering Education, Salt Lake City, Utah, June 20-23, 2004.*

Theodore J. Branoff

Ted Branoff is an associate professor of Graphic Communications in the Department of Mathematics, Science and Technology Education at North Carolina State University. He received a bachelor of science in Technical Education in 1985, a master of science in Occupational Education in 1989, and a Ph.D. in Curriculum and Instruction in 1998. His research interests include spatial visualization in undergraduate students and the effects of online instruction for preparing community college educators. Along with teaching courses in introductory engineering graphics, computer-aided design, descriptive geometry, and instructional design, he has conducted CAD and geometric dimensioning & tolerancing workshops for both high school teachers and local industry. Dr. Branoff has been an ASEE member since 1987.