

Online, Pre-Instructional Questioning Strategies: Do Formative Evaluations Correlate with End-of-Course Summative Evaluations in Engineering Graphics Courses?

Ted Branoff¹

Abstract – During the fall 2006 semester at North Carolina State University, students in an introductory engineering graphics course were asked to complete a reading assignment each week and take an online assessment before coming to class for additional instruction. The online assessments were completed using WebCT Vista. After all assessments were completed, students were asked to provide feedback by filling out a survey. Scores on the assessments were correlated with each student's homework average and midterm exam grade. This paper will discuss the design of the study and the preliminary results.

Keywords: Online, WebCT, Graphics

INTRODUCTION

As educators we use a variety of methods to facilitate student learning in engineering graphics courses. These typically include lecture, demonstration, problem-solving, sketching, 3D modeling, and reading assignments. Assessment of these methods may include paper-pencil tests, performance problems (sketching or computer-based), or online techniques. When moving from a paper-pencil test to an online assessment, instructors need to consider the role of Internet technologies in the instructional process [1]. Online assessments and measurements are only valuable when they are designed and used to produce useful information or meet productive instructional objectives [2]. For example, assessments can be used as a pre-instructional strategy to prepare students for instruction. Carefully crafted questions can be used to motivate students to read for understanding in preparation for an upcoming class.

Learning Management Systems have opened up new ways for faculty to deliver and assess instruction. The assessment components of these tools allow faculty to control when students may access a test, design the type of feedback each student gets, and automatically grade the test [3]. An online assessment is an example of an asynchronous tool which allows faculty to measure performance through a *different time-different place* mode [4] [5]. Since students can receive immediate feedback when completing an assessment, unique opportunities exist for educators to design an instructional setting where students can be more responsible for their own learning.

PARTICIPANTS

The participants in this study were 22 engineering majors enrolled in one section of an introductory engineering graphics course. Students were enrolled in the following engineering departments: aerospace engineering, mechanical engineering, civil engineering, electrical engineering, computer engineering, and paper science and engineering. Participants included 10 sophomores, 10 juniors, 1 senior and 1 continuing education student.

¹ North Carolina State University, Raleigh, NC 27695-7801, ted_branoff@ncsu.edu

ASSESSMENTS

A total of 8 online assessments were created for this study using WebCT Vista. The assessments ranged from 10-20 items, and students were required to complete them before coming to class. Multiple options for grading student assessments exist within the software [6]. For this study, students were given two attempts at each assessment. Their grade was determined by the average of the two attempts. The assessments covered the following chapters in *Fundamentals of Graphics Communication* [7]:

- Chapter 1 – Introduction to Graphics Communication
- Chapter 2 – Sketching and Text
- Chapter 3 – Engineering Geometry
- Chapter 5 – Multiviews & Visualization
- Chapter 7 – Pictorial Projections
- Chapter 8 – Section Views
- Chapter 9 – Dimensioning & Tolerancing Practices
- Chapter 10 – Working Drawings & Assemblies

Figure 1 shows an example item for Chapter 1, and Figure 2 shows an example item for Chapter 10.

8. Question 1.8

(Points: 7.0)

Identify the linetype indicated by item 1 in the figure.

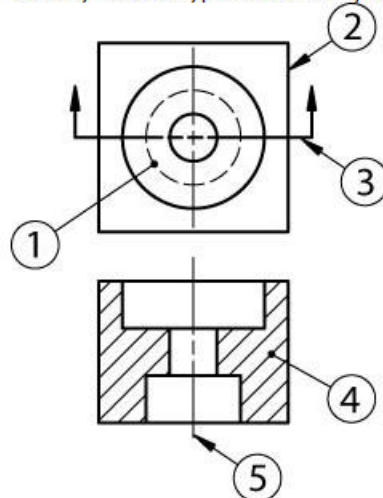

- 1. Center line
- 2. Cutting-plane line
- 3. Hidden line
- 4. Section line
- 5. Visible line

Save Next Question

Figure 1. Assessment Item from Chapter 1.

5. Question 10.5 (Points: 10)

What type of drawing is shown below?

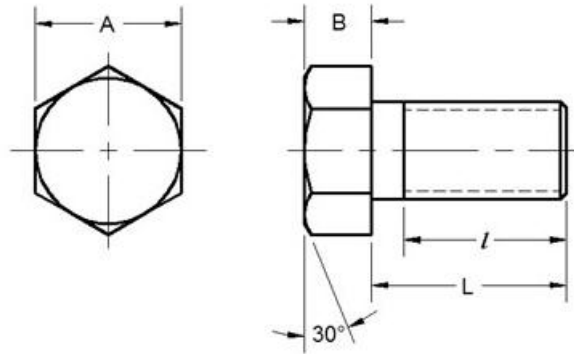

DETAIL	UNC THREAD	A	B	L	l
D-501	.500 - 13	.750	.364	1.500	1.250
D-502	.625 - 11	.938	.444	1.750	1.500
D-503	.750 - 10	1.125	.500	2.000	1.750

- 1. Assembly drawing
- 2. Bill of materials
- 3. Sectioned drawing
- 4. Tabular drawing

Save Answer

Figure 2. Assessment Item from Chapter 10.

RESULTS

Data for the online test means were plotted against each student's homework average (see Figure 3) and each student's midterm exam score (see Figure 4).

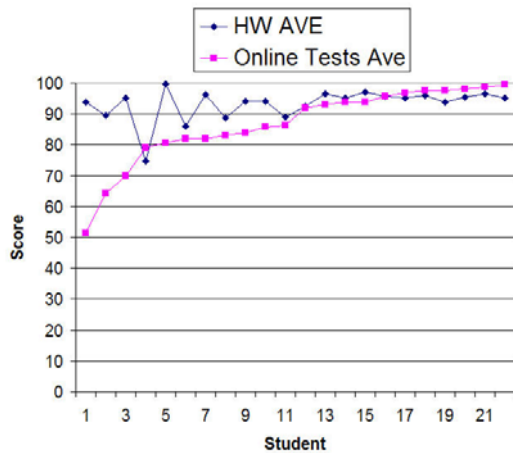

Figure 3. Online Assessments vs. Homework.

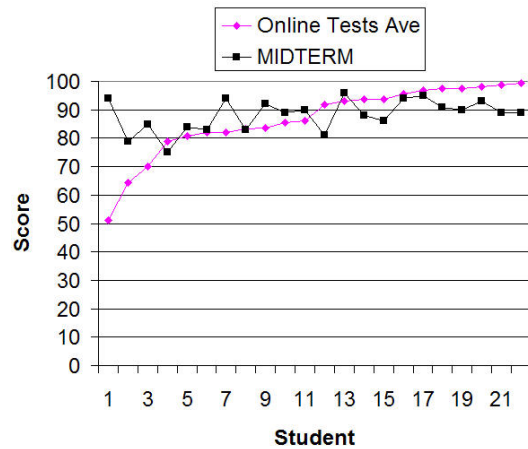

Figure 4. Online Assessments vs. Midterm Exam.

To determine if a correlation existed between the online assessments and either homework average or midterm exam score, Kendall Tau coefficients were calculated for each variable. Table 1 shows the results of the correlation analyses.

Table 1. Kendall Tau Correlation Coefficients.

Analysis	Kendall Tau
Vista Assessment Mean vs. Homework Mean	0.26638
Vista Assessment Mean vs. Midterm Exam Score	0.24835

No significant relationship existed between the Vista assessment means and homework means or between the Vista assessment means and midterm exam scores.

Students were also asked to fill out a survey after all assessments were completed. Twenty of the twenty-two students completed the survey. Table 2 displays the results of four questions related to students' preparation for class and their views about the continued use of the assessments.

Table 2. Results of Post-Assessment Survey.

<i>Did the online Vista assessments help you prepare for class?</i>	
Yes	20
No	0
Total	20
<i>Were the questions in the online Vista assessments appropriate for the material being covered?</i>	
Yes	20
No	0
Total	20
<i>Did the online Vista assessments help you prepare for the midterm exam?</i>	
Yes	18
No	2
Total	20
<i>Do you think faculty should continue to use the online Vista assessments in GC120?</i>	
Yes	20
No	0
Total	20

Students were also asked to respond to questions regarding their strategy for completing the assessments. In addition, they were asked about how they would approach reading assignments if no online assessments were required (see Table 3).

Table 3. Results of Post-Assessment Survey Relative to Strategy.

<i>Which statement best describes your typical strategy for the online Vista assessments?</i>	
I read the chapter and then completed the online Vista assessment.	2
I skimmed the chapter and then completed the Vista assessment while looking up material in the book.	12
I looked in the book for the first time as I took the online Vista assessments.	4
I took the online Vista assessment without looking at the textbook.	1
All of the above	1
Total	20
<i>If you were not required to complete online Vista assessments, which statement best describes what your strategy might have been this semester related to reading assignments?</i>	
I would probably read the assigned chapter before the topic was covered in class.	0
I would probably skim the assigned chapter before the topic was covered in class.	4
I would probably look at the chapters only when studying for the exams.	15
I would not read the chapters at all.	1
Total	20

CONCLUSION

Analyses indicated that there was no relationship between the mean of a student's online assessments and the mean of their homework. It was also determined that no relationship existed between the mean of a student's online assessments and their midterm exam score. Doing poorly on the online Vista assessments did not appear to indicate that a student would do poorly on the homework or on the midterm exam. The post-assessment survey seemed to reflect that students felt the online assessments helped them prepare for class and the midterm exam. Only 2 students reported reading the chapters completely before taking the assessments. Most students' first look at the reading material came while taking the assessment.

RECOMMENDATIONS

Although no relationships existed between the online Vista assessments and other formative measures in the course, the assessments appeared to be a useful instructional tool for helping students prepare for class and to help them study for the midterm exam. Recommendations for further study include:

- conducting the study again with a larger group from the introductory course.
- replicating the study at another university with a similar population.

References

- [1] Hricko, M., & Howell, S. L. (Eds.). (2006). *Online assessment and measurement: Foundations and challenges*. Hershey: Information Science Publishing.
- [2] Williams, D. D., Howell, S. L., & Hricko, M. (Eds.). (2006). *Online assessment, measurement, and evaluation: Emerging Practices*. Hershey: Information Science Publishing.
- [3] Branoff, T. J., & Totten, R. A. (2005). Online learning in engineering graphics courses: What are some of the big issues? *Proceedings of the 60th Annual Midyear Conference of the Engineering Design Graphics Division of the American Society for Engineering Education, Fort Lauderdale, Florida, December 4-6, 2005*.
- [4] Ashley, J. (December 2003). Synchronous and asynchronous tools. *ASAE & The Center for Association Leadership*. Retrieved November 29, 2005, from <http://www.centeronline.org/knowledge/article.cfm?ID=2587>
- [5] Branoff, T. J., & Totten, R. A. (2006). Online learning in engineering graphics courses: What are some of the big issues? *Proceedings of the 2006 Southeast Section Conference of the American Society for Engineering Education, Tuscaloosa, Alabama, April 2-4, 2006*.
- [6] Howell, S. L., & Hricko, M. (Eds.). (2006). *Online assessment and measurement: Case studies from higher education, K-12 and corporate*. Hershey: Information Science Publishing.
- [7] Bertoline, G. R., & Wiebe, E. N. (2007). *Fundamentals of graphics communication*. Boston: McGraw-Hill.

Ted J. Branoff

Ted Branoff is an associate professor of Graphic Communications in the Department of Mathematics, Science and Technology Education at North Carolina State University. He received a bachelor of science in Technical Education in 1985, a master of science in Occupational Education in 1989, and a Ph.D. in Curriculum and Instruction in 1998. His research interests include spatial visualization in undergraduate students and issues related to online instruction. Along with teaching courses in introductory engineering graphics, computer-aided design, descriptive geometry, and instructional design, he has conducted CAD and geometric dimensioning & tolerancing workshops for both high school teachers and local industry. Dr. Branoff has been an ASEE member since 1987.